



Thank you for purchasing LS Variable Frequency Drives!

## SAFETY INSTRUCTIONS

Safety instructions are prepared to use the product safely and correctly by preventing any accident or risk beforehand, so they should be always kept.

- In this manual, safety instructions are divided into two classes; each has the following meaning.

 **WARNING** Improper operation may result in serious personal injury or death.

 **CAUTION** Improper operation may result in slight to medium personal injury or property damage.

- Throughout this manual, we use the following two illustrations to make you aware of safety considerations.

 identifies potential hazards under certain conditions.

 identifies shock hazards under certain conditions.

- After reading this manual, keep it handy for any user to quickly refer to.
- Read this manual carefully to use SV-iE5 Series Inverter's functions appropriately and safely.

### **Warning**

- Do not remove the cover while the power is applied or the unit is in operation.  
Or, it may cause electric shock.
- Do not run the inverter with the front cover removed.  
Or, it may cause an electric shock due to high voltage terminals or charged capacitor exposure.
- Do not remove the cover except for periodic inspections or wiring, even if the input power is not applied.  
Or, it may cause an electric shock due to charged capacitor exposure even if the power is cut off.
- Wiring and periodic inspections should be performed at least 10 minutes after disconnecting the input power and after checking the DC link voltage is discharged with a meter (below DC 30V).  
Or, it may cause an electric shock (below DC 30V)
- Operate the switches with dry hands.  
Or, it may cause an electric shock.

## Instructions

- Do not use the cable when its insulating tube is damaged.  
Or, it may cause an electric shock.
- Do not subject the cables to any heavy load stressful to them.  
Or, it may cause an electric shock due to damaged cable.



## Caution

- Install the inverter on a non-flammable surface.  
Or, it may cause a fire if being installed on or closely to a flammable material.
- Disconnect the input power if the inverter gets damaged.  
Or, it may result in a secondary accident and fire.
- After the input power is applied or removed, the inverter will remain hot for a couple of minutes.  
Otherwise, you get bodily injuries such as skin-burn or damage.
- Do not apply power to a damaged inverter or an inverter with parts missing even if the installation is complete.  
Or, it may cause an electric shock.
- Do not allow screw, metal chips, water drops, oil or other impurities into the inverter.  
Or, it may cause a fire.

## Operating Precautions

### (1) Transport and installation

- Carry it correctly according to the specified weight.
- Do not stack the inverter boxes higher than recommended.
- Install according to instruction specified in this manual.
- Do not open the cover during transport.
- Do not place any heavy load on the inverter.
- Check whether the inverter mounting direction is correct.
- Do not drop the inverter, or subject it to impact.
- Follow your national electrical code for grounding(200V).
- As soon as detaching PCB(Printed Circuit Board) for installation or repair, make sure to place it on conductor. Otherwise, it may cause destruction due to static electricity.
- Use the inverter under the following environmental conditions.

Environment	Ambient temperature	- 10 ~ 40 °C (non-freezing)
	Relative humidity	90% RH or less (non-condensing)
	Storage temperature	- 20 ~ 65 °C
	Service condition	Free of any corrosive gas, combustible gas, oil mist or dust
	Altitude, vibration	Max. 1,000m above the sea level · 5.9m/sec <sup>2</sup> (=0.6g) or less

**(2) Wiring**

- Do not connect a power factor correction capacitor, surge suppressor, or RFI filter to the output of the inverter.
- The connection orientation of the output cables should be in good order of U, V, W.
- Incorrect terminal wiring could result in the equipment damage.
- Reversing the polarity (+/-) of the terminals could damage the inverter.
- The only authorized and skilled person should perform wiring and inspections.
- Always install the inverter before wiring.

**(3) Trial run**

- Check all parameters during operation. Changing parameter values might be required depending on the load.
- Always apply permissible range of voltage to the each terminal as indicated in this manual. Otherwise, it could lead to inverter damage.

**(4) Operation precautions**

- Note that if the Auto restart function is selected, you must stay away from the equipment as a motor will restart suddenly after an alarm stop.
- The Stop key on the keypad is activated only when the setting has been made. Prepare an emergency stop switch separately.
- If any fault is reset with the reference signal present, a sudden start will automatically occur. Check that the reference signal is turned off in advance. Otherwise an accident could occur.
- Do not modify or alter the inverter without permission.
- Do not use a magnetic contactor on the inverter input for frequent starting/stopping of the inverter.
- Use a noise filter to reduce the effect of electromagnetic interference. Otherwise nearby electronic equipment may be affected.

- In case of input voltage unbalance, install AC reactor. Power Factor capacitors and generators may become overheated and damaged due to potential high frequency noise transmitted from inverter.
- Before operating unit and prior to user programming, reset user parameters to default settings.
- Inverter can easily be set to high-speed operations, Verify capability of motor or machinery prior to operating unit.
- Stopping torque is not produced when using the DC-Break function. Install separate equipment when stopping torque is needed.

### **(5) Fault prevention precautions**

- Provide a safety backup such as an emergency brake which will prevent the machine and equipment from hazardous conditions if the inverter fails.

### **(6) Maintenance, inspection and parts replacement**

- Do not conduct a megger (insulation resistance) test on the control circuit of the inverter.

### **(7) Disposal**

- Dispose of the inverter as treating industrial waste.

### **(8) General instructions**

- Many of the diagrams and drawings in this instruction manual show the inverter without a circuit breaker, a cover or partially open. Never run the inverter like this. Always place the cover with circuit breakers and follow this instruction manual when operating the inverter.

**User's Manual**

- The purpose of this manual is to provide the user with the necessary information to install, program, start up and maintain the SV-iE5 series inverter.
- To assure successful installation and operation of the SV-iE5 series inverter, the material presented must be thoroughly read and understood before proceeding
- This manual contains.

Ch.	Title	Description
1	Basic information and Precautions	Provides general information and precautions for safe use of the inverter.
2	Installation	Provides instructions on how to install the SV-iE5 inverter.
3	Wiring	Provide the information on how to wire the input power and signal terminal strip.
4	Peripheral	Describes how to connect the optional peripheral devices to the inverter.
5	Loader	Illustrates keypad features and display.
6	Basic Operation	Provides instructions for quick start of the inverter.
7	Function List	Summarized table of functions.
8	Troubleshooting and Maintenance	Provides information on potential troubles or abnormal situations.
9	Specifications	Gives information on Input/Output rating, control type and more details of the SV-iE5 inverter.

Contents

<b>1. Basic Information and Precaution</b> .....	<b>1-1</b>
1.1 Important precautions .....	1-1
1.2 Parts' Names and Details .....	1-2
1.3 Assembling and Disassembling .....	1-3
<b>2. Installation</b> .....	<b>2-1</b>
2.1 Installation precautions .....	2-1
2.2 Dimensions .....	2-4
<b>3. Wiring</b> .....	<b>3-1</b>
3.1 Control Terminal Wiring Diagram .....	3-1
3.2 Power Terminal Wiring Diagram .....	3-1
3.3 Grounding Specification .....	3-2
3.4 Control Terminal Wiring Specification .....	3-3
3.5 PNP/NPN Modes Switch .....	3-4
<b>4. Peripheral</b> .....	<b>4-1</b>
4.1 Configuration of Peripherals .....	4-1
4.2 Recommended MCCB and Magnetic Contactor .....	4-2
4.3 Recommended Reactors .....	4-2
<b>5. Loader</b> .....	<b>5-1</b>
5.1 Configuration .....	5-1
5.2 Alpha-numeric view on the LED .....	5-2
5.3 Moving to other groups .....	5-3
5.4 How to move among codes in a group .....	5-4
5.5 How to set parameters .....	5-7
5.6 Monitoring Operation Status .....	5-9
<b>6. Basic Operation</b> .....	<b>6-1</b>
6.1 Frequency Setting and Basic Operation .....	6-1
<b>7. Function List</b> .....	<b>7-1</b>
<b>8. Troubleshooting and Maintenance</b> .....	<b>8-1</b>
8.1 Protective Functions .....	8-1
8.2 Fault Remedy .....	8-3
8.3 Precautions for maintenance .....	8-5
8.4 Checklist .....	8-5
8.5 Parts Replacement .....	8-6
<b>9. Specifications</b> .....	<b>9-1</b>
9.1 Technical data .....	9-1
<b>DECLARATION OF CONFORMITY</b> .....	오류! 책갈피가 정의되어 있지 않습니다.

1. Basic Information and Precaution

1.1 Important precautions

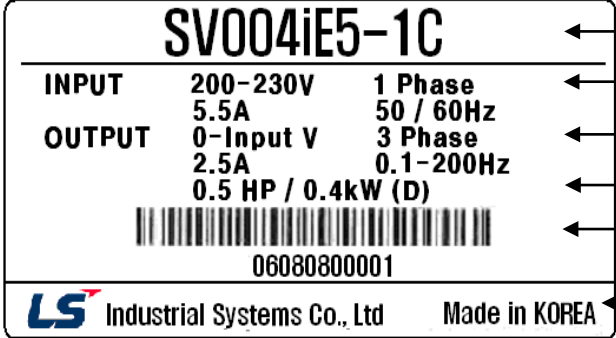
Unpacking and Inspection	Unpack the package and check the inverter type, output ratings on the nameplate and whether the inverter is intact. In addition, inspect the inverter for any damage that may have occurred during shipping.																						
 <p style="text-align: right;">             ← Inverter type              ← Rated Input spec.              ← Rated output spec.              ← Inverter capacity              ← Barcode and serial number              ← Manufacturer and Manufacturing country         </p>																							
<p style="text-align: center;"><b>SV            004                    iE5            -                    1                    C</b></p> <table border="1" style="width: 100%; border-collapse: collapse;"> <thead> <tr> <th colspan="2">Motor rating</th> <th>Series name</th> <th colspan="2">Input power</th> <th colspan="2">RS-485 option</th> </tr> </thead> <tbody> <tr> <td>001</td> <td>0.1 [kW]</td> <td rowspan="3">Extra small commercial inverter</td> <td>1</td> <td>Single</td> <td>C</td> <td>No</td> </tr> <tr> <td>002</td> <td>0.2 [kW]</td> <td rowspan="2">2</td> <td rowspan="2">3 Phases 200V</td> <td rowspan="2">-</td> <td rowspan="2">No option</td> </tr> <tr> <td>004</td> <td>0.4 [kW]</td> </tr> </tbody> </table>		Motor rating		Series name	Input power		RS-485 option		001	0.1 [kW]	Extra small commercial inverter	1	Single	C	No	002	0.2 [kW]	2	3 Phases 200V	-	No option	004	0.4 [kW]
Motor rating		Series name	Input power		RS-485 option																		
001	0.1 [kW]	Extra small commercial inverter	1	Single	C	No																	
002	0.2 [kW]		2	3 Phases 200V	-	No option																	
004	0.4 [kW]																						
<p>● Accessories</p> <p>If you have found any discrepancy, damage, etc., contact your dealer or sales representative (refer to the rear cover page of this manual).</p>																							
Preparations of instruments and parts required for operation	Instruments and parts to be prepared depend on how the inverter is operated. Prepare optional (additional) equipments and parts as necessary.																						
Installation	To operate the inverter with high performance for a long time, install the inverter considering a proper place and the correct direction with proper clearances.																						
Wiring	Connect the power supply, motor and operation signals (control signals) to the terminal block. Note that incorrect connection may damage the inverter and peripheral devices.																						

## 1.2 Parts' Names and Details

- Appearance

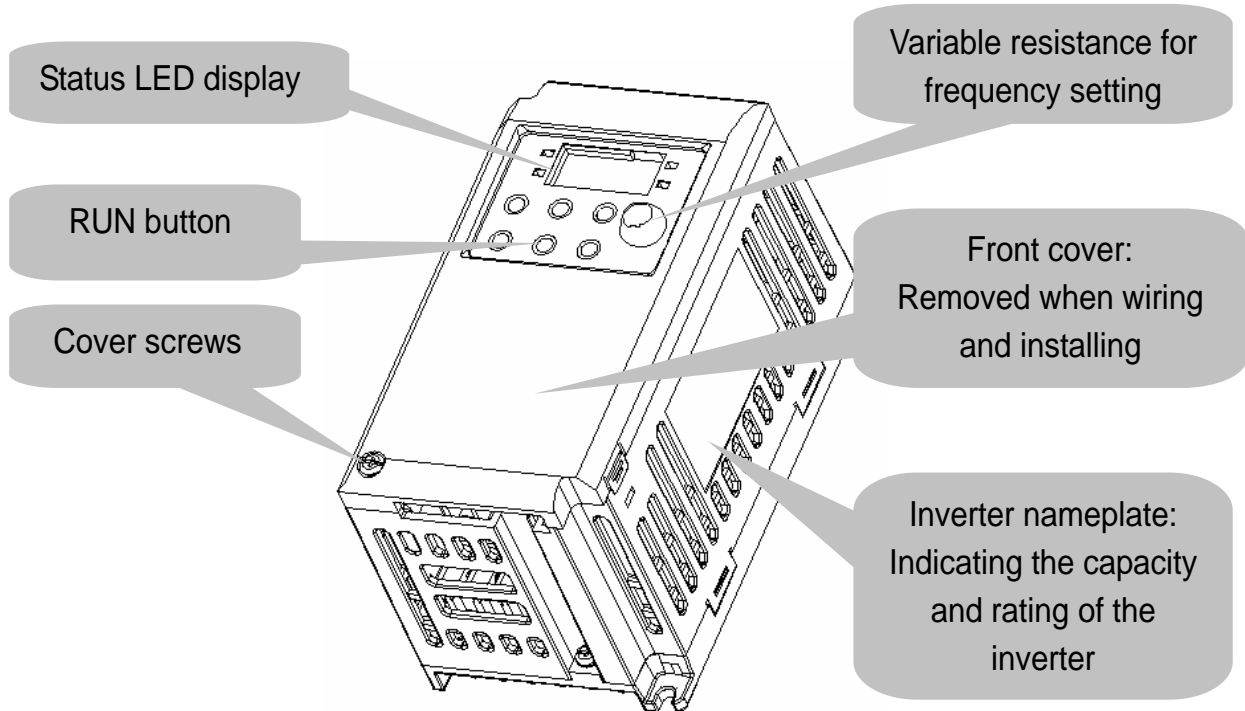

- Inside view with front cover removed

Refer to 1.3 for details when remove front cover.

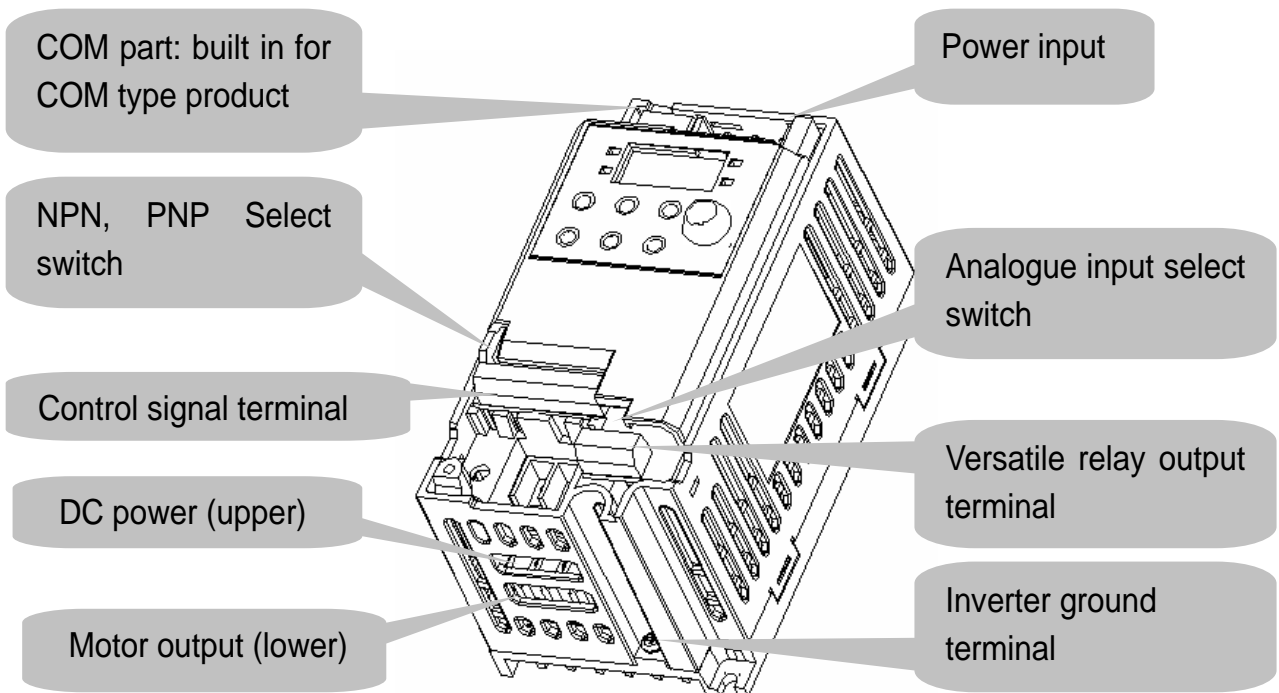



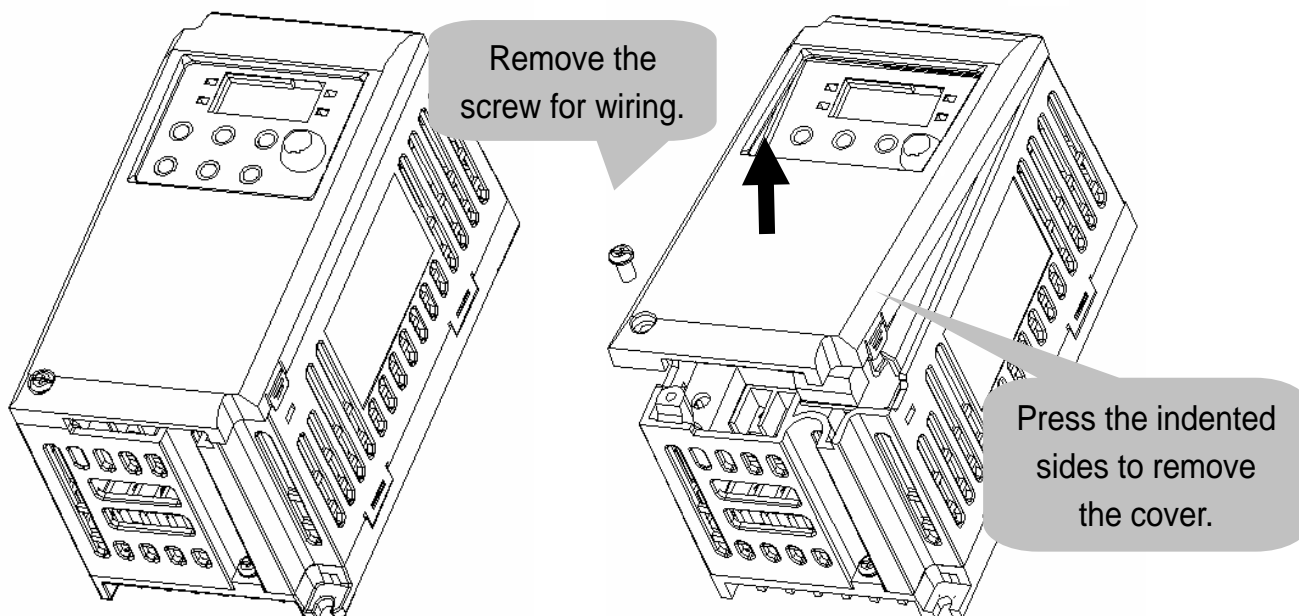

### 1.3 Assembling and Disassembling

- To remove the front cover, press both indented sides of the cover lightly and pull it up.

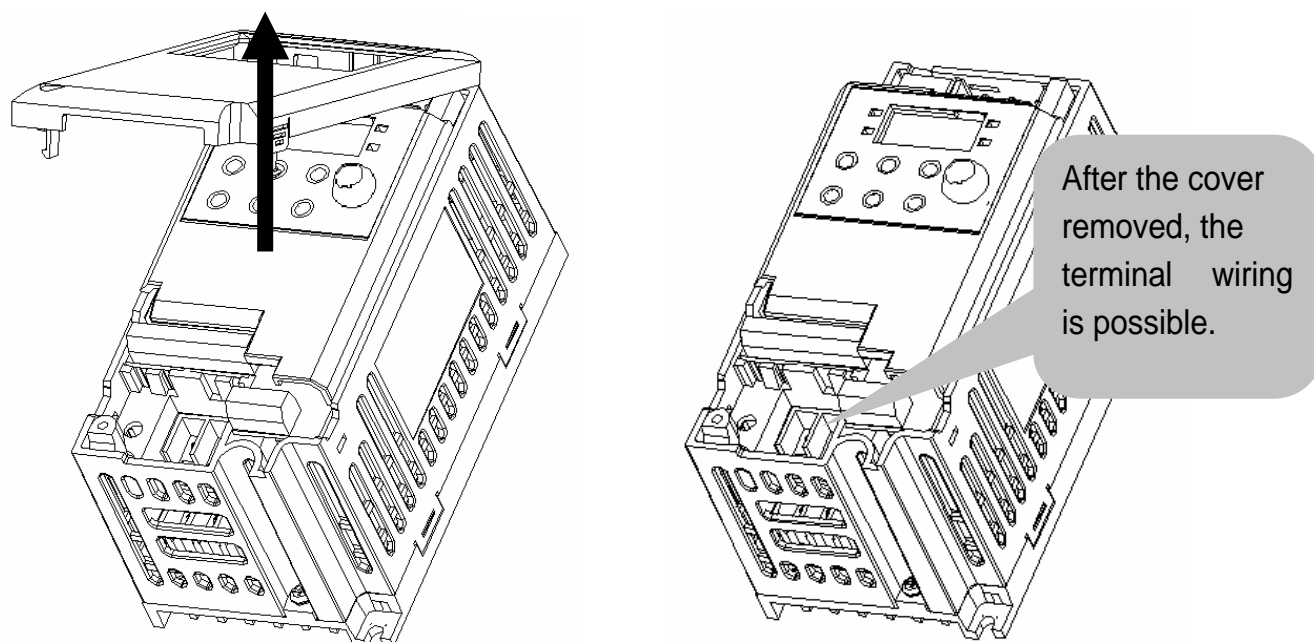

- The front cover is completely removed if lifting it up and removing the fixed part. Wiring and installation is available only with the cover removed.



<p>Caution</p> 	<p>For the control terminal, use the cables presented in this manual. Using a thicker one than the reference type may interfere with assembling or subject the cable sheath to damage.</p>
--	--



## 2. Installation

### 2.1 Installation precautions

#### ! CAUTION

- Handle the inverter with care to prevent the plastic components damaged.
- Avoid installing the inverter in a place where vibration from bogie or press exists.
- Install in a location where ambient air temperature is within the permissible range (-10 ~ 40°C).
- Maximum Surrounding Air Temperature of 40 °C (UL508C)

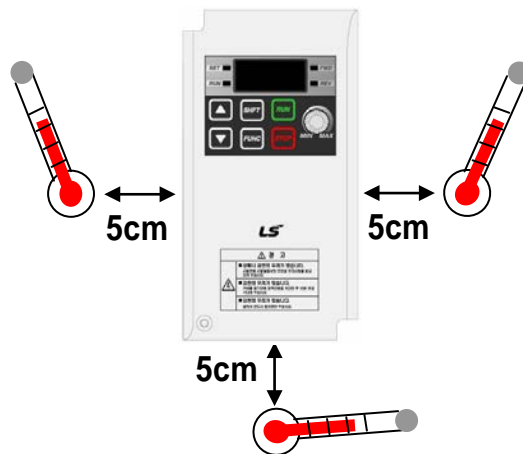

< Ambient air Temp Checking Location >

- The inverter will be very hot during operation. Install it on a flame-retardant surface.
- Inverter is a heating source, so the installation place needs enough space for proper heat dissipation.
- In case installed in a panel without ventilating opening, secure space as presented in Figure 1.
- If the inverters are installed in a row, make sure to leave space between and among them as seen in Figure 2. Note that side space may vary depending on a panel's cooling efficiency.

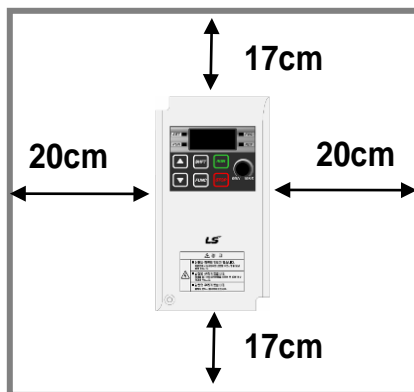

[Figure 1]

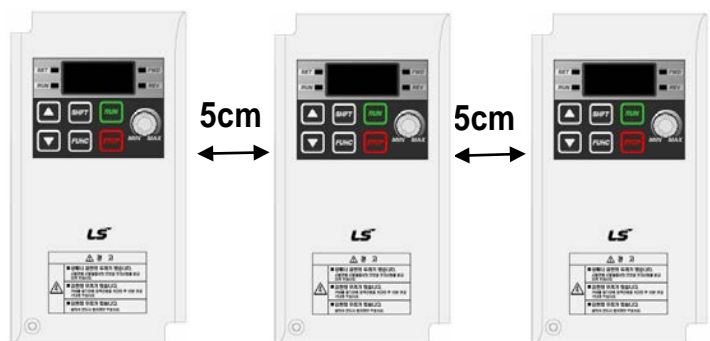

[Figure 2]

## Chapter 2. Installation

- Protect from high temperature and high moisture and/or direct sunlight.
- Install the inverter inside a “totally enclosed” panel to protect against oil mist, water or dust.
- When two or more inverters are installed inside a panel, the inverters and fans must be installed in proper positions with extreme care.
- Install the inverter using screws or bolts to insure the inverter is firmly fastened.

< For installing multiple inverters in a panel >

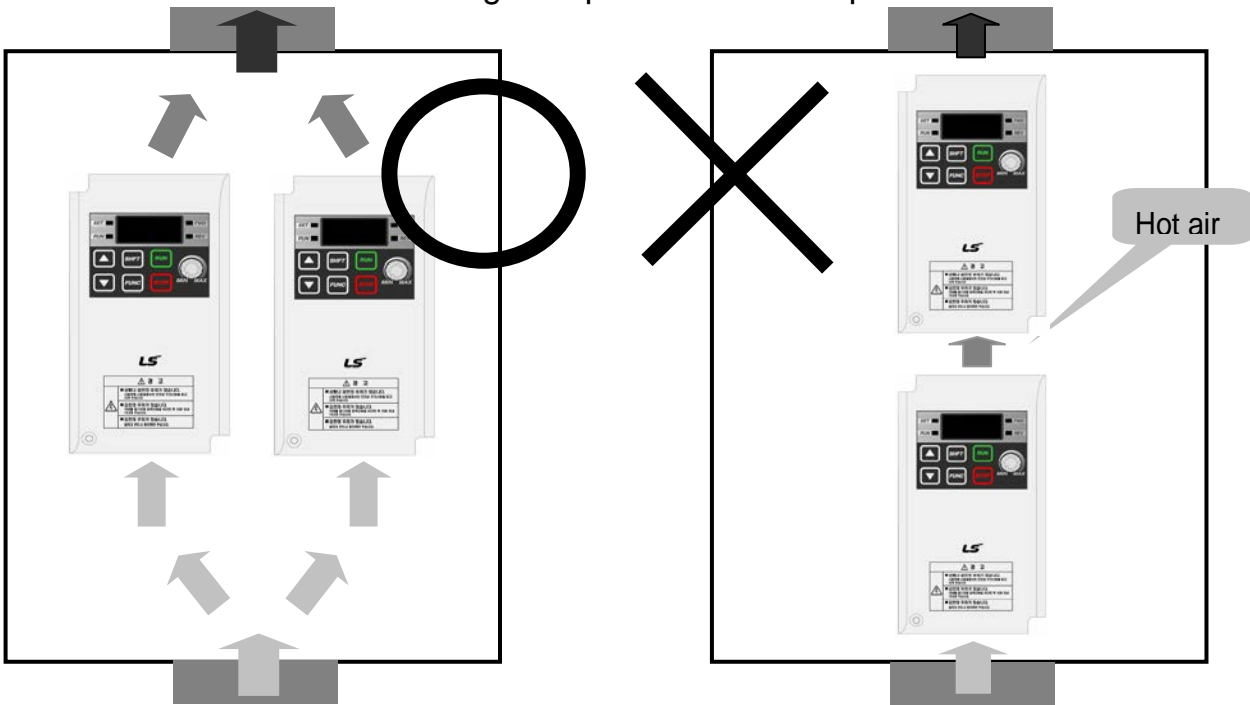

Caution

Arrange hot air from the inverters is discharged when installing them on a panel. 'X' shows incorrect layout example.

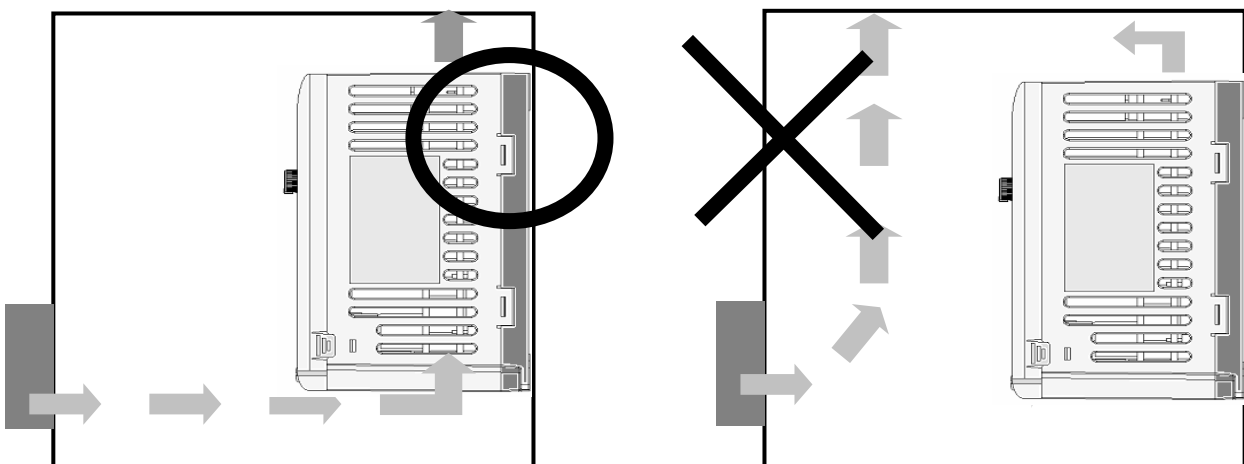

Caution

A fan is to be installed so that the air inside the inverter is well discharged as seen in the left figure. 'X' shows an example of reduced cooling effect, possibly causing the inverter to overheat.



## Warning

- Follows procedure below when Install the inverter for successful operation.

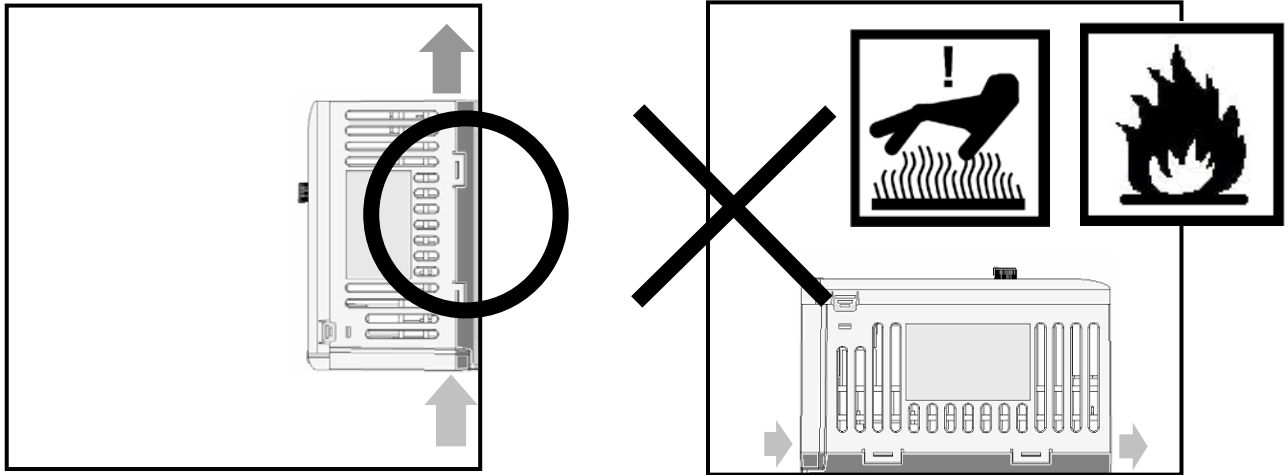

Caution

iE5 has self cooling structure using air. Therefore install the inverter vertically possible to air circulation. Malfunction or fire may be caused when installed horizontally.

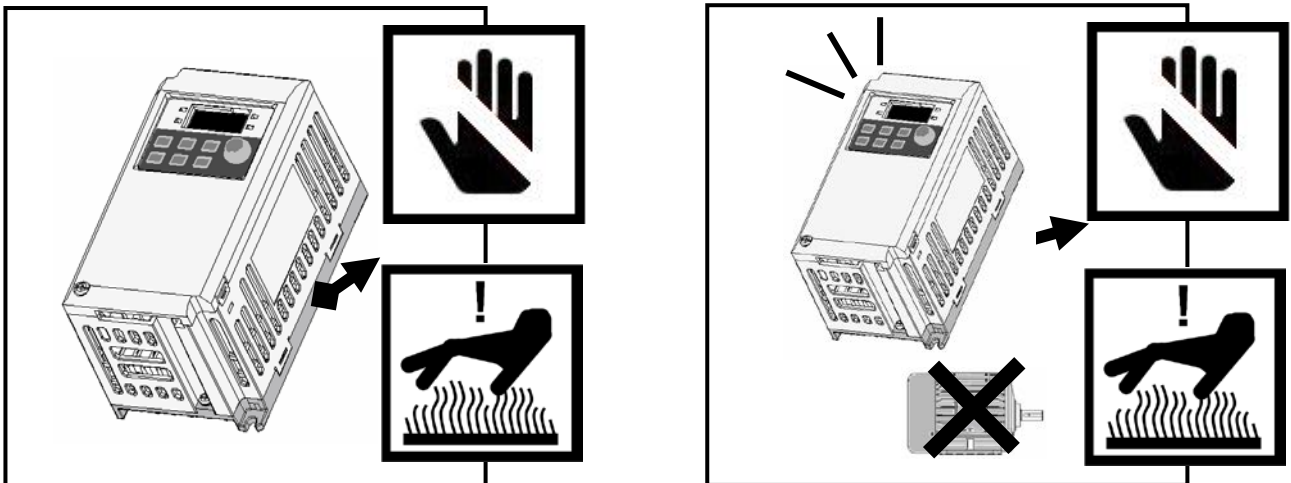

Caution

- Heat protection pin of iE5 is a high heating element. Caution to contact while operate the products.
- Since switching heat occurs when inverter output without connection motors, Do not operate inverter independently. Skin burn or malfunction may be caused.

## 2.2 Dimensions

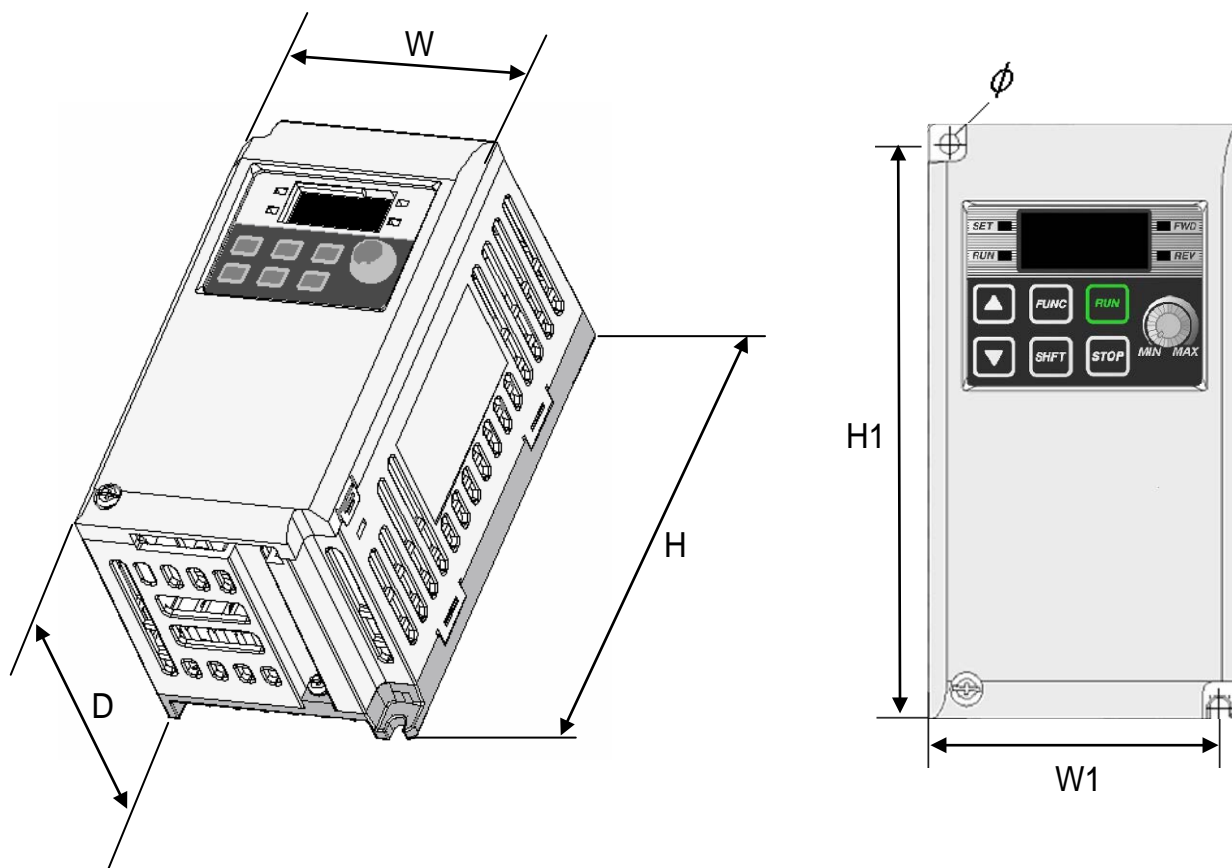

Inverter	001iE5-1	002iE5-1	004iE5-1	001iE5-2	002iE5-2	004iE5-2
W	68	68	68	68	68	68
H	128	128	128	128	128	128
D	85	85	115	85	85	115
H1	124	124	124	124	124	124
W1	64	64	64	64	64	64
φ	4.2	4.2	4.2	4.2	4.2	4.2
Weight(kg)	0.44	0.46	0.68	0.43	0.45	0.67

### Note

Use M4 screw for fixing the inverter on a panel.

### 3. Wiring

#### 3.1 Control Terminal Wiring Diagram

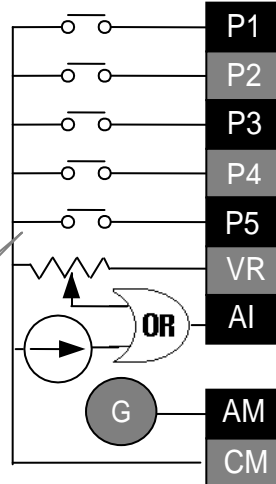
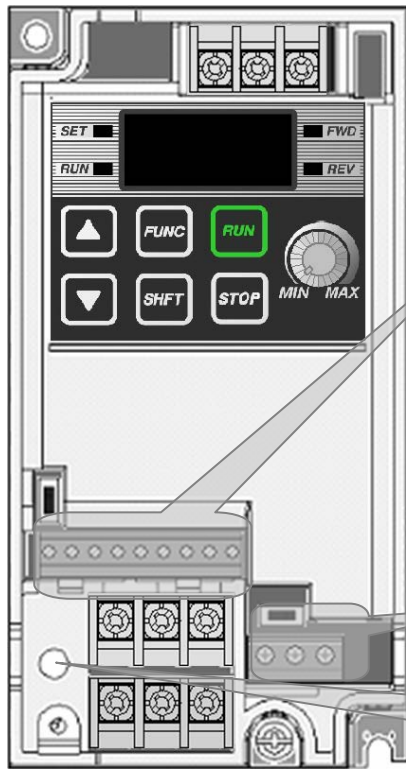

T/M	Description	
P1	Multi function terminal	FX : forward run
P2		RX : reverse run
P3		EST : emergency stop
P4		RST : trip reset
P5		JOG : jog operation
VR	12V power(12V,100mA) for external volume	
AI	Analogue frequency input(Voltage or current)	
AM	Analogue output: 0 ~ 10V	
CM	Input signal common	
30A	Multi function relay output terminal	A contact output
30B		B contact output
30C		A/B contact common

Power-indicative lamp

#### Note

Refer to page 3-3 for the dimensions of the control terminal.

#### 3.2 Power Terminal Wiring Diagram

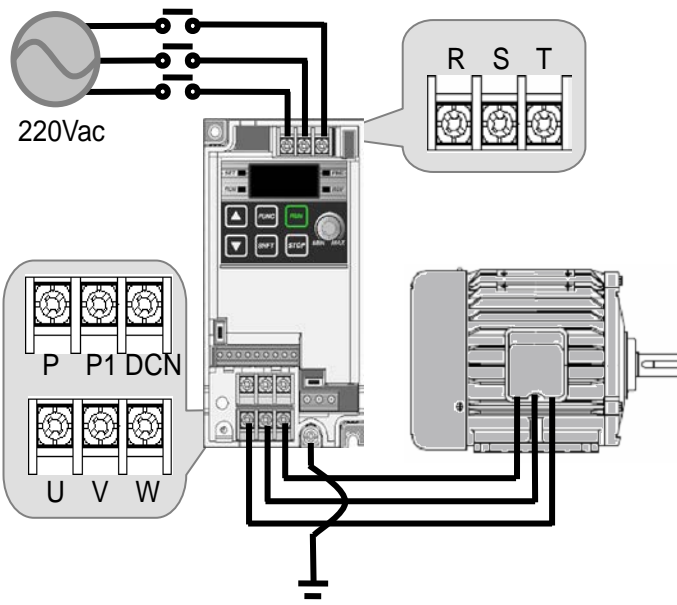

#### 0.1~0.4kW IE5 Power Terminal Specification

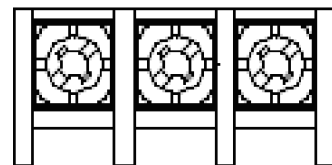

I wire thickness	16AWG, 1.25 mm <sup>2</sup>
O wire thickness	16AWG, 1.25 mm <sup>2</sup>
G wire thickness	14AWG, 1.25 mm <sup>2</sup>
I/O terminal	16AWG, 1.25 mm <sup>2</sup> /3.5 φ
Terminal torque	3.5 lb-in



Caution

In case of single phase, the input power should be connected to R, S terminals. If connected to T phase, the inverter does not work.



**⚠ CAUTION**

- Suitable For Use On A Circuit Capable of Delivering Not More Than 5000 RMS Symmetrical Amperes, 240 Volts Maximum. (UL508C)
- Use Copper Conductors Only, 75 °C only with a torque rating. (UL508C)
- Make sure the input power is off before wiring.
- When the inverter's input power is cut off after operation, wire it after DC circuit voltage inside the inverter is fully discharged by measuring P1 and N with a tester (voltmeter). If there is no tester, wire it after the power lamp is completely out.
- Applying input power supply to the output terminals U, V and W causes internal inverter damage.
- Use ring terminals with insulated caps when wiring the input power and motor wiring
- Do not leave wire fragments inside the inverter. it can cause faults, breakdowns and malfunctions.
- Never short P1 or P with N. Shorting terminals may cause internal inverter damage.
- Do not connect static condenser, surge killer or radio noise filter to the output of the inverter. Otherwise, the inverter's protection function starts working or it may cause condenser or surge suppressor broken.
- The inverter is delivered that P~P1 are connected to short circuit.

**3.3 Grounding Specification**

**⚠ WARNING**

- Use the Type 3 grounding method (Ground impedance: Below 100Ω).
- Use the dedicated ground terminal to ground the inverter. Do not use the screw in the case or chassis, etc for grounding.

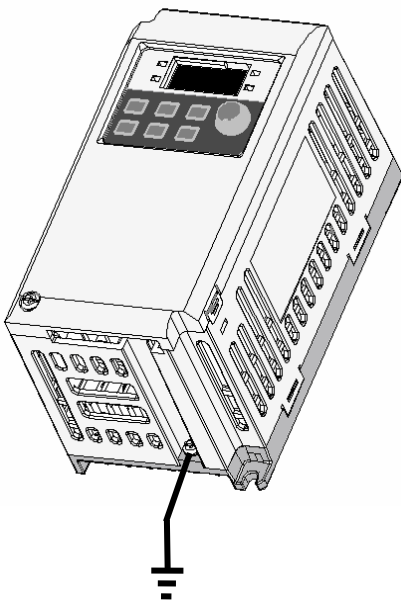

**Note**

- Grounding procedure
  - 1) Remove the front cover.
  - 2) Connect the Grounding wire to the ground terminal as shown above.

**⚠ CAUTION**

Follow the grounding specifications.

Inverter Cap.	001iE5, 002iE5, 004iE5 – 1, 2
Wire size	14AWG, 2mm <sup>2</sup>
Lug spec.	14AWG, 2mm <sup>2</sup> , 4φ
Grounding method	Special type 3

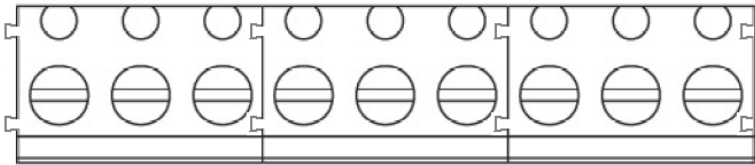
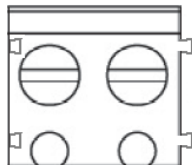

### 3.4 Control Terminal Wiring Specification

Terminal description			COM optional terminal							
										
P1	P2	P3	P4	P5	VR	AI	AM	CM	S+	S-
T/M	Terminal description	Wire size	Torque [lb-in]	Remarks						
P1~P5	Multi-function input T/M 1-5	22 AWG,0.3 mm <sup>2</sup>	3.0	-						
VR	Power T/M for external volume resistance	22 AWG,0.3 mm <sup>2</sup>	3.0	-						
AI	Analogue frequency input T/M	22 AWG,0.3 mm <sup>2</sup>	3.0	-						
AM	Multi-function output T/M	22 AWG,0.3 mm <sup>2</sup>	3.0	-						
CM	Common terminal	22 AWG,0.3 mm <sup>2</sup>	3.0	-						

#### Multi-function Relay T/M Spec.

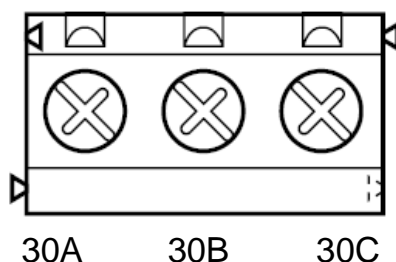

T/M	Terminal description	Wire size	Torque[lb-in]	Remarks
30A	Multi-function relay output A contact	20 AWG,0.5 mm <sup>2</sup>	4.5	-
30B	Multi-function relay output B contact	20 AWG,0.5 mm <sup>2</sup>	4.5	-
30C	Common for Multi-function relays	20 AWG,0.5 mm <sup>2</sup>	4.5	-

#### CAUTION

Tie the control wires more than 15cm away from the control terminals. Otherwise, it interferes with front cover reinstallation.

#### Note

When you use external power supply (24V) for multi-function input terminal (P1~P5), terminals will be active above 12V level. Take caution not to drop the voltage below 12V.

### 3.5 PNP/NPN Modes Switch

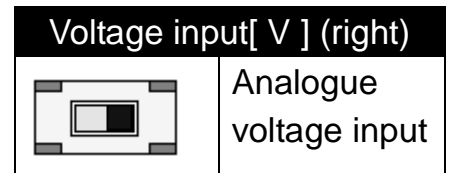
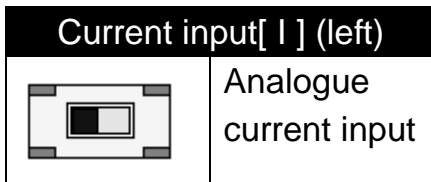
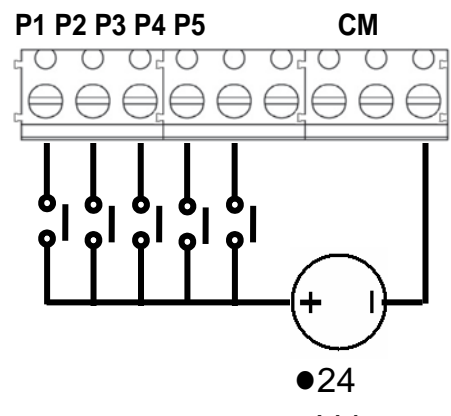
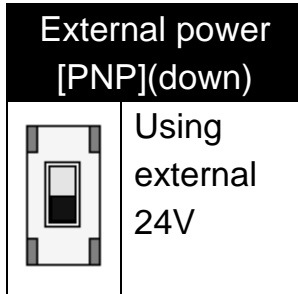
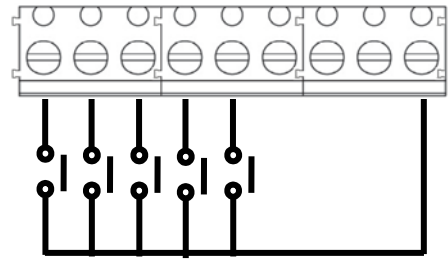
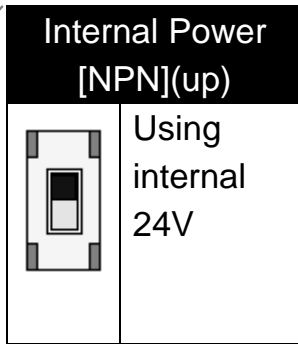
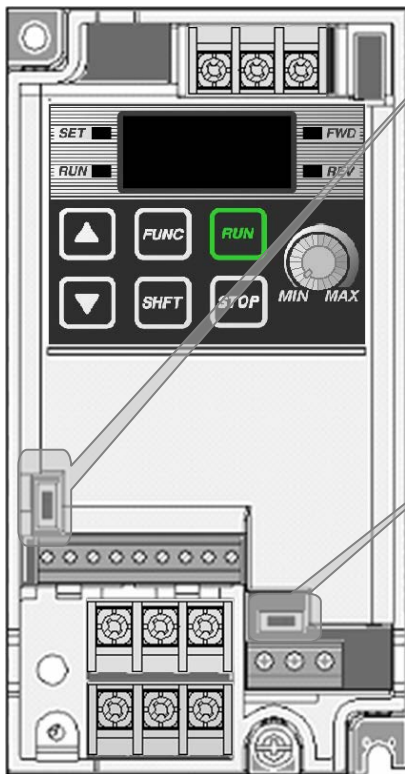

1) Using external current

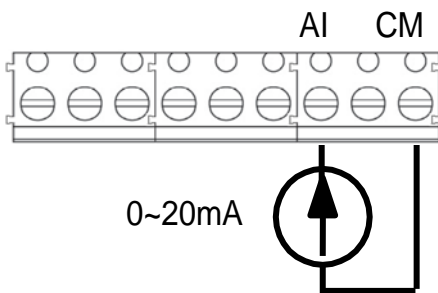

2) Using external voltage

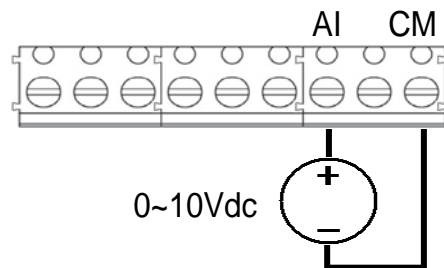

**Note**

The setting direction of switch in the above figure is in black.

3) Using variable resistor

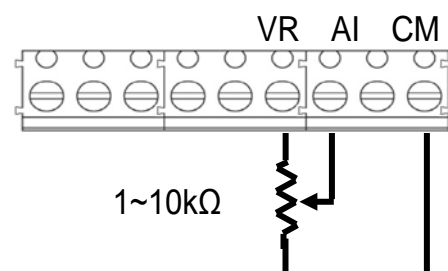





## 4. Peripheral

### 4.1 Configuration of Peripherals

Correct peripherals must be selected and properly connected. An incorrectly applied or installed inverter may result in system malfunction or reduction in product life as well as component damage. You must read and understand this manual thoroughly before proceeding.

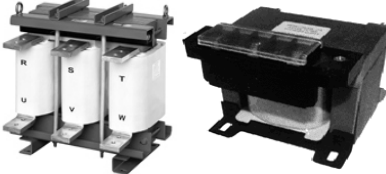
- AC power input

Peripheral	Name	Caution
	Input power	Use the power supply within the permissible range of inverter input power rating (Refer to Page 15-1).
	MCCB or ELB	Select circuit breakers with care. A large inrush current may flow in the inverter at power on.
	Magnetic contactor	Install it if necessary. When installed, do not use it for the purpose of starting or stopping. Otherwise, it may cause the reduction of product life.
	AC or DC reactors	The reactors must be used when the power factor is to be improved or the inverter is installed near a large power supply system (20times and more than its cap. and wiring distance within 10m).
	Installation and wiring	Maintain the ambient temperature within the permissible range because the life is sensitive to the temperature. Incorrect terminal wiring could result in equipment damage.
	Inverter output	Do not connect a static condenser, surge suppressor or radio noise filter to the output side of the inverter.

### 4.2 Recommended MCCB and Magnetic Contactor

Model	MCCB (LSIS)			ELB (LSIS)		MC (LSIS)		
001iE5-1	ABS33c	3A	UTE100	15A	EBS33c	5A	MC-6a	9A
002iE5-1		3A		15A		5A		
004iE5-1		5A		15A		5A		
001iE5-2		3A		15A		5A		
002iE5-2		5A		15A		5A		
004iE5-2		10A		15A		10A		

### 4.3 Recommended Reactors

Model	AC Input fuse	AC reactor	DC reactor
001iE5-1	20A	4.2mH, 3.5A	10mH, 3A
002iE5-1			
004iE5-1		5.1mH, 5.4A	7mH, 5A
001iE5-2		4.2mH, 3.5A	10mH, 3A
002iE5-2			
004iE5-2			7mH, 5A

## 5. Loader

### 5.1 Configuration



FWD/REV LED  
SET LED  
RUN LED  
7-Segment LED

UP, DOWN  
SHFT  
FUNC  
RUN, STOP/RESET  
Volume Resistance

#### Note

STOP key of the inverter iE5 also contains reset function, which is used to cancel trip. Trip may be cancelled by using this key.

Display	Description	Remark
FWD	'On' during forward run	Blinks when a fault occurs
REV	'On' during reverse run	
SET	'On' during parameter setting	
RUN	'On' during inverter operation	
7 Segments	Displaying operation status and parameter information	

Key	Name	Description
▲	Up	Scroll through codes or increase parameter value
▼	Down	Scroll through codes or decrease parameter value
RUN	Run	Operation command
STOP	Stop	STOP : stop during operation, RST : reset in case of fault
FUNC	Function	Edit parameters or save edited parameter values
SHFT	Shift	Move among groups/the number of ciphers left during parameter setting
Volume resistance		Used to change driving frequency

### 5.2 Alpha-numeric view on the LED

Refer to the below table summarizing the characters displayed on the LED.

Inverter LED	No.	Inverter LED	Eng.	Inverter LED	Eng.	Inverter LED	Eng.
0	0	A	A	K	K	U	U
1	1	b	B	L	L	V	V
2	2	C	C	M	M	W	W
3	3	d	D	N	N	X	X
4	4	E	E	O	O	Y	Y
5	5	F	F	P	P	Z	Z
6	6	G	G	Q	Q		
7	7	H	H	R	R		
8	8	I	I	S	S		
9	9	J	J	T	T		

**Note**

Inverter iE5 uses 7-segment display. Therefore, it displays numbers and alphabet as the above table. Make sure to fully comprehend them for reading the fault messages/functional information.

**Note**

The 7-Segment operates in three statuses; on, off and blink. Throughout this manual, on is in black, blank is in grey and off is not separately presented.

i.e.)

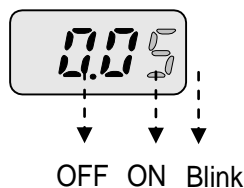

### 5.3 Moving to other groups

- There are two different parameter groups in SV-iE5 series as shown below.

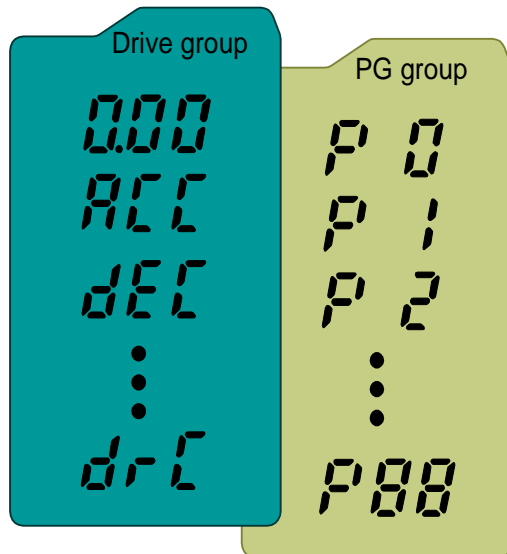

Type	Description
Drive group	Basic parameters necessary to operate the inverter; target frequency, acceleration/deceleration time and etc.
PG group	Parameter group for additional functions

#### Moving to the other parameter group

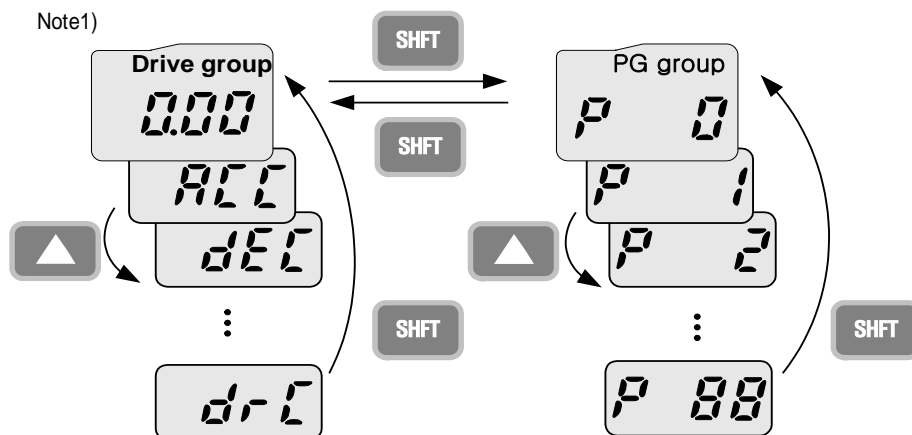

Can move between groups if pressing SHFT key in code 0 of Drive Group/PG Group as shown in the figure. If pressing SHFT in other codes but 0, it moves to the first code of a selected group and it moves between groups if pressing SHFT once more.

<sup>1)</sup> Target frequency is set in the first code of Drive Group. It is delivered with 0.00 set as the default and any differently changed driving frequency is displayed once a user changes it.

### 5.4 How to move among codes in a group

- Moving between groups

#### Moving from 15 of PG Group to Drive Group

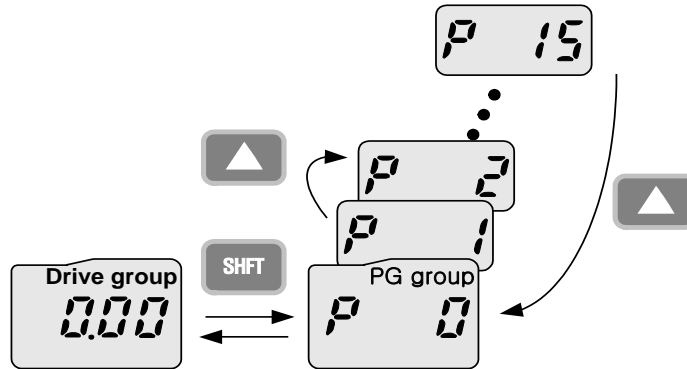

1		- . Display Code 15 of PG Group. - . Press SHFT key.
2		- . It displays F0, the first code of PG Group. - . Press SHFT key.
3		- . It displays 0.00, the first code of Drive Group.

- Code change in Drive Group

<p>The diagram illustrates the process of moving through the codes of a Drive group. It shows five stages of the display: 1. '0.00', 2. 'drC', 3. 'dEC', 4. 'drC', and 5. '0.00'. Arrows indicate the sequence of key presses: UP, UP, UP, UP, DOWN.</p>	1		- . It displays 0.00, the 1st code of Drive Group. - . Press UP(▲) key.
	2		- . It displays ACC, the 2nd code of Drive Group. - . Press UP(▲) key.
	3		- . It displays dEC, the 3rd code of Drive Group. - . Keep pressing UP(▲) key.
	4		- . It displays drC, the final code of Drive Group - . Press UP(▲) key in the final code of Drive Group.
	5		- . It returns to the 1st code of Drive Group.

**Note**

For moving reversely, use DOWN(▼) key.



● Code jump

Moving from code 1(P 0) to the code15(P15) in PG Group

	1		- It displays P0, the 1st code of Drive Group. - Press FUNC key.
	2		- SET lamp lights up. Changeable number blinks - It shows moving to Code 1 is possible. Set 5 using UP(▲) key.
	3		- The 1st digit is changed to 5. - Press SHFT key. - Blinking cursor moves and 05 is displayed. Change it to 1 using UP(▲) key.
	4		- It shows moving to Code 15 is possible. - Pressing FUNC key enters 15.
	5		- SET lamp is out. - It displays Code 15 of PG Group.

● Code change in PG Group

Moving from code 1 to code 15 in PG group

	1		- It displays Code 1 of PG Group. - Keep pressing UP(▲) key until P 15 is displayed.
	2		- It displays Code 15 of PG Group.

**Note**

Some codes will be skipped in the middle of increment (▲)/decrement (▼) for code change in PG Group. That is because it is programmed that some codes are intentionally reserved for later use or the codes user does not use are invisible.

## Chapter 5. Loader

- Frequency setting

When changing RUN frequency to 30.05 [Hz] in Drive Group

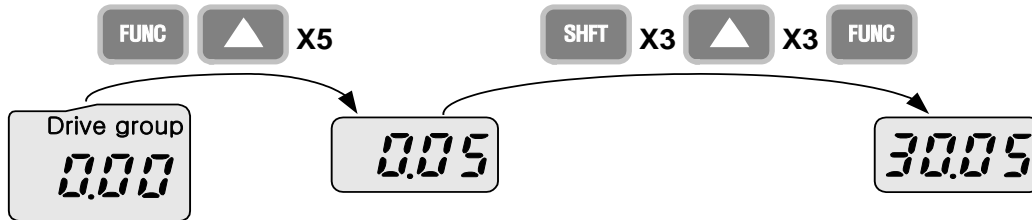

1		- It displays Target Frequency, the 1st code of Drive Group. - Press FUNC key.
2		- SET lamp lights up. - The second decimal 0 becomes active. - Press the UP (▲) key until 5 is displayed.
3		- The second decimal is changed to 5. - Press SHFT key.
4		- The first decimal 0 becomes active. - Press SHFT key twice.
5		- The first digit 0 becomes active. - Set 3 using UP(▲) key.
6		- Press FUNC key.
7		- 30.05 blinks quickly and it asks whether to save the value. - Press FUNC key.
8		- SET lamp is out. - Blink stops and the saved target frequency are displayed.

### Note

Parameter setting is disabled when pressing other Keys except Function Key(FUNC) in step 6 where 30.05 blinks quickly.

## 5.5 How to set parameters

### ● Parameter change in Drive Group

#### Changing acceleration duration from 5.0 to 16.0 seconds

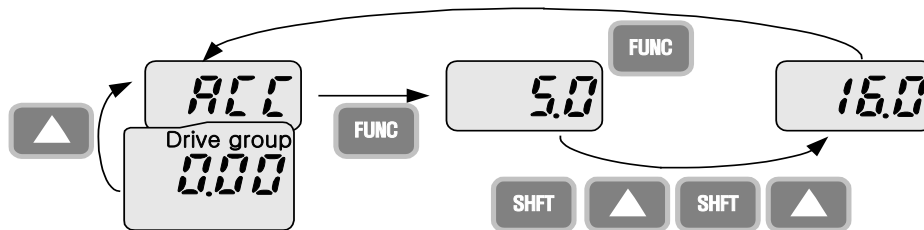

1		- It displays the target frequency, the 1st code of Drive Group. - Press UP(▲) key.
2		- It displays ACC, the acceleration duration, the 2nd code of Drive Group. - Press Function(FUNC) key.
3		- SET lamp lights up. - 0 in 5.0 blinks, which means that the digit may be changed. - Press Shift(SHFT) key.
4		- The digit to change is moved to the first digit. - Press UP(▲) key.
5		- The digit to change is increased, being changed to 6.0. - Press Shift(SHFT) key.
6		- The digit to change is moved the tenth digit. - Press UP(▲) key.
7		- It displays 16.0. - Press Function(FUNC) key. - 16.0 blinks wholly. <sup>1)</sup> - Press Function(FUNC) key. ACC duration of 16.0 seconds is entered.
8		- SET lamp is out. - It displays ACC. ACC duration is changed to 16.0 seconds.

<sup>1)</sup> That every digit blinks quickly while modifying a parameter means asking whether to enter a modified value. At the moment, pressing Function(FUNC) key completes the entry. To cancel it instead of entering a parameter, press any key such as Shift(SHFT), UP(▲) or DOWN(▼) but Function(FUNC) key.

● Parameter change in PG Group

**Changing P34, Code 34 of PG Group from 0 to 1**

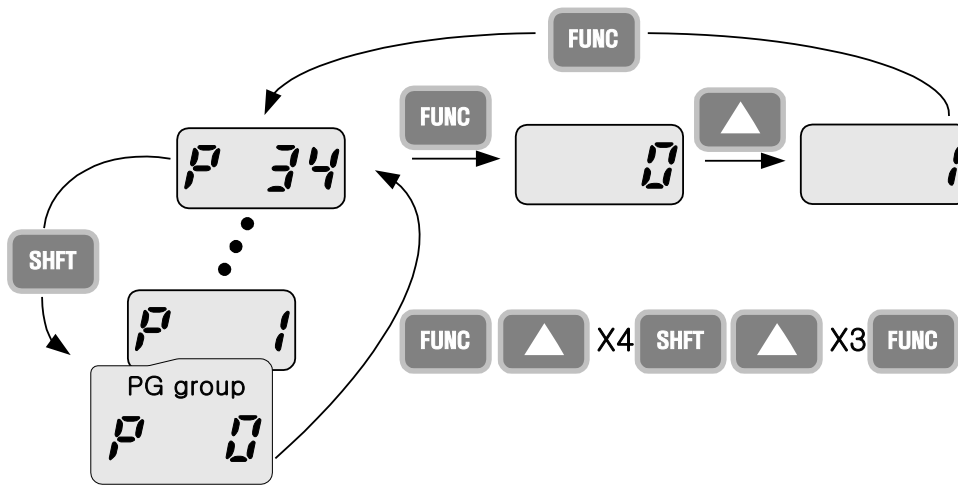

1		- . The 1st code of PG Group is displayed. - . Press FUNC key.
2		- . SET lamp lights up. - . Can move to Code 1. - . Chang it to 4 by using UP(▲) key.
3		- . The first digit is changed to 4 - . Press SHFT key.
4		- . 0 in 04 is active. - . Increase up to 3 by using UP(▲) key.
5		- . Can move to Code 34. - . Press FUNC key.
6		- . SET lamp is out. - . It means the current position is Code 34 of PG Group. - . Press FUNC key.
7		- . SET lamp light up. - . Code 34 is set to 0. - . Increase it to 1 by using UP(▲) key.
8		- . Press FUNC key. - . Press FUNC key once more when 1 blinks. - . SET lamp is out.
9		- . Function code change is complete. - . Press SHFT key.
10		- . Moved to Code 1 of PG Group.

## 5.6 Monitoring Operation Status

- Displaying Current Output

### Monitoring output current in Drive Group

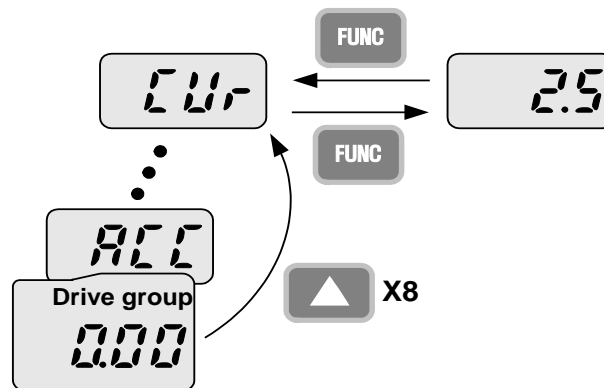

1		- The target frequency, Code 1 of Drive Group is displayed. - Press UP(▲) key or DOWN(▼) key until Cur is displayed.
2		- Moved to a code to monitor output current. - Press FUNC key.
3		- Present output current is 2.5[A]. - Press FUNC key.
4		- Return to the output current monitoring code.

#### Note

Other parameters in Drive group such as dCL (Inverter DC link voltage) or vOL (Inverter output voltage) can be monitored via the same method.

- Fault display

## How to monitor fault condition in Drive Group

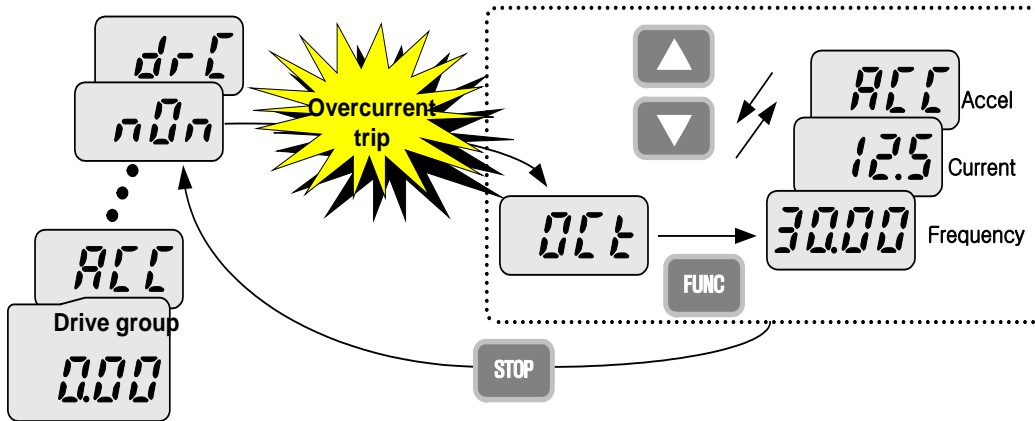

1		<ul style="list-style-type: none"> <li>- OCL appears when an Overcurrent fault occurs.</li> <li>- Press FUNC key.</li> <li>- Press UP(▲) key or DOWN (▼) key.</li> </ul>
2		<ul style="list-style-type: none"> <li>- The run frequency at the time of trip is displayed.</li> <li>- Press UP(▲) key.</li> </ul>
3		<ul style="list-style-type: none"> <li>- The output current at the time of trip is displayed.</li> <li>- Press UP(▲) key.</li> </ul>
4		<ul style="list-style-type: none"> <li>- Operating status is displayed. A fault occurred during acceleration.</li> <li>- Press STOP key.</li> </ul>
5		<ul style="list-style-type: none"> <li>- A fault condition is cleared and "nOn" is displayed.</li> </ul>

### Note

Trip occurrence is displayed in one of modes like ACC, DEC, Stp or Std. Fault causes may be expected by using the indication.

- When types of faults occur at the same time

When Overcurrent(Oc), overvoltage(Ovt) and overheat(OHt) occur simultaneously

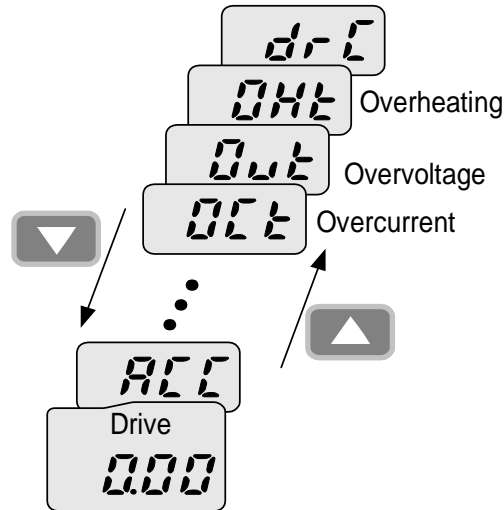

- When various trips occur simultaneously, it shows like the figure above and it can show up to 3 trips.

#### Note

In case inverter trip occurs, it shows the type in the current fault status indication code. In the case, if clearing it away by resetting or turning it off, fault info is moved to fault history(P 1) of PG Group.

However, if any, the existing fault history moves from (P 1) to (P 2) or from (P 2) to (P 3); the latest fault info is saved in (P 1) through (P 3).

**MEMO**

A large rectangular area with horizontal dashed lines, intended for writing a memo.



## 6. Basic Operation

### 6.1 Frequency Setting and Basic Operation

#### Note

The following parameters are set to factory defaults. Therefore, results may be different if any parameter is changed by a user. In this case, initialize parameters back to factory defaults and follow the instructions below.

- If setting frequency with the loader and commanding operation on the inverter's terminal

No.	Indication	Operation and description
1		- Target frequency, the first code of Drive Group when turning it on. - Press FUNC key.
2		- The second decimal, 0 in 0.00 displayed blinks. - Press SHFT three times.
3		- 00.00 is displayed and the very left 0 blinks. - Press UP(▲) key.
4		- Confirming 10.00, press FUNC key. - 10.00 blinks quickly as a whole. Press FUNC key once more.
5		- Target frequency is changed to 10.00Hz. - Turn on the switch between P1(FX) and CM terminals.
6		- FWD(forward run) lamp of the inverter display blinks and accelerating frequency is displayed on the LED. - When target run frequency 10Hz is reached, 10.00 is displayed. - Turn off the switch between P1 (FX) and CM terminals.
7		- FWD lamp begins to blink and decelerating frequency is displayed on the LED. - When run frequency is reached to 0Hz, RUN and FWD lamp turn off and target frequency (10.00) is displayed.

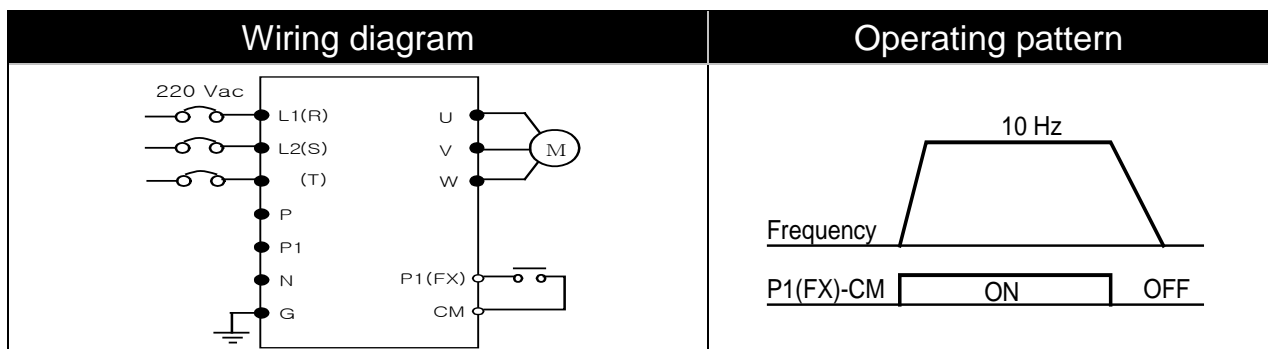

## Chapter 6. Basic Operation

- If setting frequency with volume resistance on the loader and commanding operation on the inverter's terminal

No.	Indication	Operation and description
1		- Target frequency, the first code of Drive Group when turning it on. - Press UP(▲) key four times.
2		- Moved to a code to change a frequency setting mode. - Press FUNC key.
3		- The current frequency setting mode is set to 0(frequency setting using loader). - Press UP(▲) key two times.
4		- Check 3(frequency setting by loader's volume resistance). - Press FUNC key. - 3 blinks quickly. Press FUNC key once more.
5		- Frq is displayed and frequency setting mode is changed to loader volume. - Press SHFT moves to target frequency, the first code of Drive Group. - Turn the loader volume to MAX or MIN to set to 10.00Hz.
6		- Turn on the switch between P1 (FX) and CM. - FWD(forward run) lamp of the inverter display blinks and accelerating frequency is displayed on the LED. - When run frequency 10Hz is reached, the value is displayed as shown left. - Turn off the switch between P1 (FX) and CM terminals.
7		- FWD(forward run) lamp of the inverter display blinks and decelerating frequency is displayed on the LED. - When run frequency is reached to 0Hz, Run and FWD lamp turn off and target frequency(10.00)is displayed

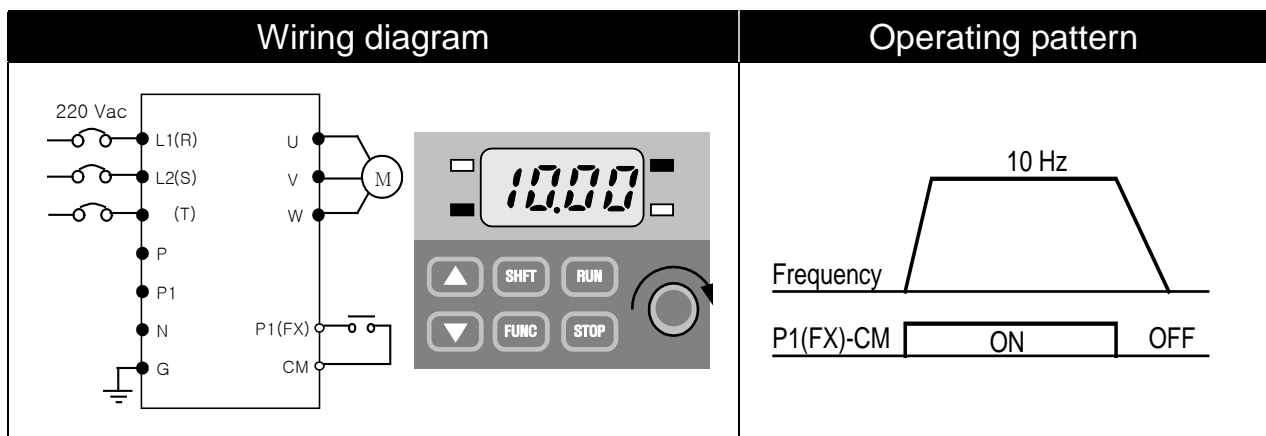

- If setting frq with volume resistance on the loader and commanding operation with RUN key on the loader

No.	Indication	Operation and description
1		- Target frequency, the first code of Drive Group when turning it on. - Press UP(▲) key three times.
2		- Moved to a code to change a frequency setting mode - Press FUNC key.
3		- The current frequency setting mode is set to 1 (terminal) - Press DOWN (▼) key.
4		- Operation command mode may be changed to 0 (RUN key of the loader). - Press FUNC key twice.
5		- It displays drv and operation command mode is changed to RUN key. - Press UP(▲) key once.
6		- Moved to frequency setting mode (Frq) code. - Press FUNC key.
7		- Frequency setting mode is changed to 0 (keypad of the loader). - Press UP(▲) key two times.
8		- Frequency setting mode may be changed to 3 (loader's volume resistance). - Press FUNC key twice.
9		- It displays Frq and frequency setting mode is changed to loader volume. - Turn the loader volume to set to 10.00 in either Max or Min direction.
10		- Press RUN key. FWD (forward run) lamp of the inverter display blinks and accelerating frequency is displayed on the LED. - When run frequency 10Hz is reached, it is displayed as shown left. - Press STOP key.
11		- FWD (forward run) lamp of the inverter display blinks and decelerating frequency is displayed on the LED. - When run frequency 10Hz is reached, FWD (forward run) lamp is out and target frequency (10.00) is displayed on the LED.

# Chapter 6. Basic Operation

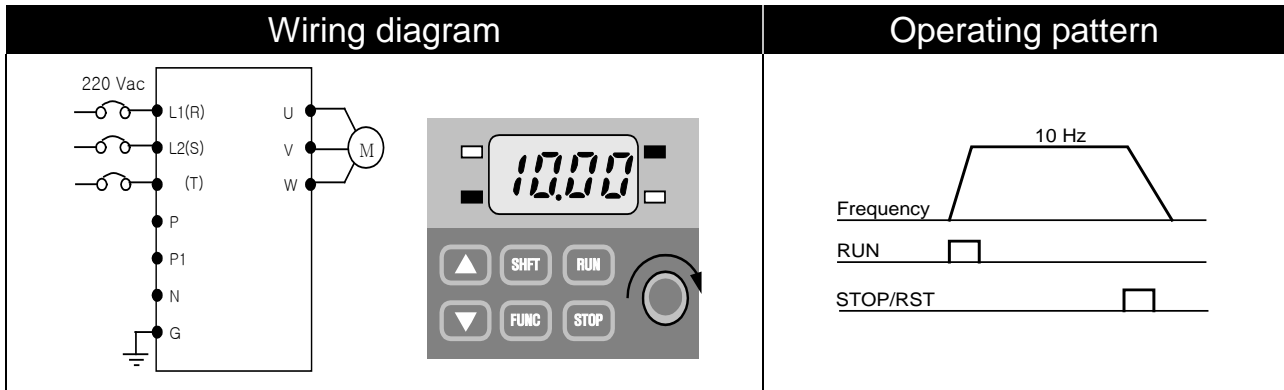

## 7. Function List

Display	Name	Min/Max range	Description		Factory defaults	Adj. during run	
0.0	Frequency command	0 ~ 200 [Hz]	This parameter sets the operation frequency. During stop, it displays Frequency Command; During run, it shows output frequency. During multi-step operation, it becomes frequency 0. It cannot be set greater than Max frequency(P16).		0.00	O	
ACC	Acc time	0 ~ 6000 [sec]	During multi-acc/dec operation, this parameter serves as acc/dec time 0.		5.0	O	
dEC	Dec time				10.0	O	
drv	Drive mode	0 ~ 3	0	Operate with RUN/STOP key of the loader	1	X	
			1	Terminal operation			FX: forward run
							RX: reverse run
			2				FX: Run/stop command
3		RX: Reverse rotation					
			3	communication: communication option			
Frq	Frequency setting method	0 ~ 4	0	Digital	0	X	
							Set loader digital frequency 1
			1				Set loader digital frequency 2
			2	Analogue			Terminal AI input
							Loader volume resistance
communication option							
4							
St1	Multi-step frequency 1	0 ~ 200 [Hz]	Set multi-step frequency 1		10.00	O	
St2	Multi-step frequency 2		Set multi-step frequency 2		20.00	O	
St3	Multi-step frequency 3		Set multi-step frequency 3		30.00	O	

## Chapter 7. Function List

- Drive Group

Display	Name	Min/Max range	Description	Factory defaults	Adj. during run	
CUr	Output current	-	Display output current	-	-	
rPM	No. of motor rotation	-	Display the no. of motor rotation(RPM)	-	-	
dCL	Inverter DC voltage	-	Display DC voltage inside the inverter	-	-	
vOL	Output voltage	-	Display the inverter's output voltage.	vOL	-	
nOn	Fault display	-	Display the types of fault, frequency, current and operation status.	-	-	
drC	Selection of motor rotation direction	F, r	If operation command mode(drv) is set to 0, select the direction of motor rotation	P	O	
			F			Forward operation
			r			Reverse operation

Display	Name	Min/Max range	Description		Factory defaults	Adj. during run
P 0	Jump code	0 ~ 88	Sets the code number to jump		1	○
P 1	Fault log 1	-	It logs the information on the types of faults, and the frequency, current and status such as acceleration, deceleration and stop at the time of trouble. The latest fault is automatically recorded in log 1.		nOn	-
P 2	Fault log 2	-	-		nOn	-
P 3	Fault log 3	-	-		nOn	-
P 4	Fault log removal	0 ~ 1	Remove log P1~P3.		0	○
P 5	Prohibition of forward/reverse rotation	0 ~ 2	0	Both F/R directions available	0	X
			1	Forward rotation prohibited		
			2	Reverse rotation prohibited		
P 6	Acc pattern	0 ~ 1	0	Linear pattern operation	0	X
P 7	Dec pattern		1	S-curve pattern operation		
P 8	Stop mode selection	0 ~ 2	0	Deceleration to stop	0	X
			1	DC brake to stop		
			2	Free run to stop		
P 9 <sup>1)</sup>	DC brake start frequency	0.1 ~ 60 [Hz]	It sets DC brake start frequency. It cannot be set below start frequency(P18).		5.00	X
P10	DC brake wait time	0 ~ 60 [sec]	When DC brake frequency is reached, the inverter holds the output for the setting time before starting DC brake.		0.10	X
P11	DC brake voltage amount	0 ~ 200 [%]	It sets the amount of DC voltage applied to a motor. Motor rated current(P43).		50	X
P12	DC brake time	0 ~ 60 [sec]	It sets the time taken to apply DC current to a motor.		1.0	X

<sup>1)</sup> Displayed only when P8 is set to 1(DC brake to stop).

## Chapter 7. Function List

Display	Name	Min/Max range	Description	Factory defaults	Adj. during run	
P13	DC brake start voltage	0 ~ 200 [%]	It sets the amount of DC voltage before a motor starts to run. Motor rated current(P43)	50	X	
P14	DC brake start time	0 ~ 60 [sec]	It applies the current to a motor for the set time before motor accelerates.	0.0	X	
P15	Jog frequency	0 ~ 200 [Hz]	It sets the frequency for jog operation. It cannot be set above the max frequency(P16).	10.00	O	
P16	Max frequency	40 ~ 200 [Hz]	<p>This parameter sets the upper limit frequency. It is frequency reference for Accel./Decel.</p> <p><b>Note</b> If changing the max frequency, all other frequency parameters but P17(base frequency) would be changed to the frequency if they are above the new max. frequency.</p>	60.00	X	
P17	Base frequency	30 ~ 200 [Hz]	The inverter outputs its rated voltage to the motor at this frequency.	60.00	X	
P18	Start frequency	0.1 ~ 10 [Hz]	<p>The inverter starts to output its voltage at this frequency. It is lower frequency limit of frequency(Hz).</p>	0.5	X	
P19	Torque boost selection	0 ~ 1	0	Manual torque boost	0	X
			1	Auto torque boost		
P20	Forward torque boost	0 ~ 15 [%]	Torque boost amount of motor during forward run, based on max. output voltage.		5.0	X
P21	Reverse torque boost		Torque boost amount of motor during reverse run based on max. output voltage.			
P22	V/F pattern	0 ~ 1	0	Linear	0	X
			1	Square		



Display	Name	Min/Max range	Description	Factory defaults	Adj. during run			
P23	Output voltage adjustment	40 ~ 110 [%]	It adjusts the amount of output voltage, based on the percentage of input voltage.	100	X			
P24	Overload trip selection	0 ~ 1	This parameter turns off the inverter output when motor is overloaded. Overload protection function works if it is set to 1.	1	0			
P25 <sup>1)</sup>	Overload trip level	50 ~ 200 [%]	It sets the amount of overload current, based on the percentage of Motor rated current(P43)	180	0			
P26	Overload trip time	0 ~ 60 [sec]	It turns off the inverter output when overload trip level current(P25) flows for overload trip time.	60	0			
P27	Stall prevention select	0 ~ 7	Sets stall prevention function				0	X
			Func. Set	During dec.	During constant run	During acc.		
				bit 2	bit 1	bit 0		
			0	-	-	-		
			1	-	-	✓		
			2	-	✓	-		
			3	-	✓	✓		
			4	✓	-	-		
			5	✓	-	✓		
6	✓	✓	-					
7	✓	✓	✓					
P28	Stall prevention level	30 ~ 150 [%]	It sets the amount of current to activate stall prevention function, based on the percentage of the motor rated current(P43).	150	X			
P29	Save up/down frequency	0 ~ 1	It decides whether to save the specified frequency during up/down operation. If 1 is selected, the up/down frequency is saved in P30.	0	X			
P30 <sup>2)</sup>	Save Up/Down	-	It saves the frequency before the inverter stops or decelerated.	0.00	-			

<sup>1),2)</sup> Set P24 and P29 to 1 to display this parameter.

## Chapter 7. Function List

Display	Name	Min/Max range	Description	Factory defaults	Adj. during run																																								
P31	Dwell frequency	0.1 ~ 200 [Hz]	When run frequency is issued, motor starts to accelerate after dwell frequency is applied to the motor during dwell time(P32). It can be set within max frequency(P16) and start frequency(P18).	5.00	X																																								
P32	Dwell time	0~10 [sec]	Sets the time for dwell operation.	0.0	X																																								
P33	Operator's fault detection	0 ~ 7 [bit]	Sets fault detection items at operator's discretion	0	O																																								
			<table border="1"> <thead> <tr> <th>Func.</th> <th>Earth detection during run(GCt)</th> <th>Input phase detection (CoL)</th> <th>Output phase detection (Pot)</th> </tr> <tr> <th>Set</th> <th>bit2</th> <th>bit1</th> <th>bit0</th> </tr> </thead> <tbody> <tr> <td>0</td> <td>-</td> <td>-</td> <td>-</td> </tr> <tr> <td>1</td> <td>-</td> <td>-</td> <td>✓</td> </tr> <tr> <td>2</td> <td>-</td> <td>✓</td> <td>-</td> </tr> <tr> <td>3</td> <td>-</td> <td>✓</td> <td>✓</td> </tr> <tr> <td>4</td> <td>✓</td> <td>-</td> <td>-</td> </tr> <tr> <td>5</td> <td>✓</td> <td>-</td> <td>✓</td> </tr> <tr> <td>6</td> <td>✓</td> <td>✓</td> <td>-</td> </tr> <tr> <td>7</td> <td>✓</td> <td>✓</td> <td>✓</td> </tr> </tbody> </table>			Func.	Earth detection during run(GCt)	Input phase detection (CoL)	Output phase detection (Pot)	Set	bit2	bit1	bit0	0	-	-	-	1	-	-	✓	2	-	✓	-	3	-	✓	✓	4	✓	-	-	5	✓	-	✓	6	✓	✓	-	7	✓	✓	✓
			Func.			Earth detection during run(GCt)	Input phase detection (CoL)	Output phase detection (Pot)																																					
			Set			bit2	bit1	bit0																																					
			0			-	-	-																																					
			1			-	-	✓																																					
			2			-	✓	-																																					
			3			-	✓	✓																																					
			4			✓	-	-																																					
5	✓	-	✓																																										
6	✓	✓	-																																										
7	✓	✓	✓																																										
P34	Power On Start Selection	0 ~ 1	It is activated when drv is set to 1 or 2. Motor starts acceleration after AC power is applied while FX or RX terminal is ON.	0	X																																								
P35	Restart after fault reset selection	0 ~ 1	It is activated when drv is set to 1 or 2 (Run/Stop via Control terminal). Motor accelerates after the fault condition is reset while the FX or RX terminal is ON.	0	O																																								

Display	Name	Min/Max range	Description	Factory defaults	Adj. during run				
P36	Speed search selection	0 ~ 15 [bit]	It is active to prevent any possible fault when the inverter outputs its voltage to the running motor.	0	X				
			Func .			Power on start (P34)	Restart after instant power failure	Operati on on after fault (P35)	Normal acc.
			Set			bit3	bit2	bit1	bit0
			0			-	-	-	-
			1			-	-	-	✓
			2			-	-	✓	
			3			-	-	✓	✓
			4			-	✓	-	-
			5			-	✓	-	✓
			6			-	✓	✓	-
			7			-	✓	✓	✓
			8			✓	-	-	-
			9			✓	-	-	✓
			10			✓	-	✓	-
			11			✓	-	✓	✓
			12			✓	✓	-	-
			13			✓	✓	-	✓
14	✓	✓	✓	-					
15	✓	✓	✓	✓					
P37	Speed Search Current Level		Limits the amount of current during speed search operation, based on motor rated current(P43)	100	O				

## Chapter 7. Function List

Display	Name	Min/Max range	Description	Factory defaults	Adj. during run
P38	Number of Auto Restart try	0 ~ 10	It sets the number of restart tries after a fault occurs. Auto Restart is deactivated if the fault outnumbers the restart tries. This function is active when [drv] is set to 1 or 2 {Run/Stop via control terminal}.	0 <sup>1)</sup>	O
P39	Auto Restart time	0 ~ 60 [sec]	Restart tries after auto restart waiting time has passed.	1.0	O
P40	Motor cap. select	0.1~ 0.4 [kW]	Selects the capacity of a motor to use.	2)	X
P41	Number of motor poles	2 ~ 12	It is displayed via rpm in drive group.	4	X
P42	Rated slip frequency	0 ~ 10 [Hz]	Enter the difference between the input power frequency and the value calculated by converting rpm described in the nameplate to frequency.	3)	X
P43	Motor rated current	0.0~ 25.5 [A]	Enter motor rated current on the nameplate.	-	X
P44	No Load Motor Current	0.0 ~ 25.5 [A]	Enter the current value detected when the motor is rotating in rated rpm after the load connected to the motor shaft is removed. Enter the 50% of the rated current value when it is difficult to measure No Load Motor Current.	-	X
P45	Carrier frequency select	1 ~ 10 [kHz]	It selects the audible sound of the motor. If the set value is higher, the inverter sound is quieter but the noise from the inverter and leakage current will become greater.	3	O

<sup>1)</sup> No auto restart in case of protection functions such as OHt, Lvt, ESt, HWt.

<sup>2)</sup> P40 initial value is preset based on inverter rating.

<sup>3)</sup> P42 ~ P44 values are changed based on the P40. factory defaults are set based on the inverter capacity.

Display	Name	Min/Max range	Description		Factory defaults	Adj. during run
P46	Control mode selection	0 ~ 2	0	V/F control	0	X
			1	Slip compensation control	-	-
			2	PI control	-	-
P47 <sup>1)</sup>	P gain for PI controller	0~ 999.9 [%]	It sets the gains for the PI controller's response characteristics.		300.00	O
P48	I time for PI controller	0.1~32.0 [sec]			1.00	O
P50	F gain for PI controller	0 ~ 99.99 [%]	Feed forward gain for PI controller.		0.00	O
P51	Upper limit of PI frequency	0.1 ~ 200 [Hz]	It limits the amount of the output frequency through the PI operation. It is settable within the range of Max frequency(P16) and Start frequency(P18).		60.00	O
P52	Lower limit of PI frequency	0.1 ~ 200 [Hz]			0.50	O
P53	Power on display	0 ~ 15	It selects the parameter to be displayed first on the display of inverter when the power is applied.		0	O
			0	Operation frequency		
			1	Acc. time		
			2	Dec. time		
			3	Drive mode		
			4	Frequency mode		
			5	Multi-step frequency 1		
			6	Multi-step frequency 2		
			7	Multi-step frequency 3		
			8	Output current(Cur)		
			9	Motor rpm		
			10	Inverter DC voltage(DCL)		
			11	User display select(vOL)		
			12	Fault display 1		
			13	Direction of motor rotation		
14	Output current					
15	Motor rpm					

1) Displayed only when P46 is set to 2(PI control).

## Chapter 7. Function List

Display	Name	Min/Max range	Description	Factory defaults	Adj. during run
P54	Gain for Motor rpm display	1 ~ 1000 [%]	It can monitoring on the rpm display code of drive group as converting gear ratio of load system.	100	0
P55	Filter time constant for AI input	0 ~ 9999	Adjusts the responsiveness of analogue input.	10	0
P56	Min input for AI(vol/cur)	0 ~ 100 [%]	Sets the min value of analogue input as the percentage of the whole input.	0	0
P57	Frequency corresponding min input for AI	0 ~ 200 [Hz]	Frequency in case analogue input is the min value.	0.00	0
P58	AI max input	0 ~ 100 [%]	Sets the max value of analogue input as the percentage of the whole input.	100	0
P59	Frequency corresponding to AI max input	0 ~ 200 [Hz]	Frequency in case analogue input is the max. value.	60.00	0
P60	Filter time constant for Volume input	0 ~ 9999	Adjusts the responsiveness of volume input operation.	10	0
P61	Min value for volume input	0 ~ 100 [%]	Sets the min rpm of volume input as the percentage of the whole input.	0	0
P62	Frequency corresponding to volume input	0 ~ 200 [Hz]	Frequency at minimum current of volume input.	0.00	0
P63	Max. value of volume input	0 ~ 100 [%]	Sets the max volume input as the percentage of the whole input.	100	0
P64	Frequency corresponding to volume input	0 ~ 200 [Hz]	Frequency at maximum volume input.	60.00	0
P65	Criteria for Analog Input Signal loss	0 ~ 2	0: Disabled 1: activated below half of set value. 2: activated below set value.	0	0

Display	Name	Min/Max range	Description					Factory defaults	Adj. during run		
P66	Multi-function input terminal P1 define	0 ~ 24	0	Forward run command (FX)					0	0	
			1	Reverse run command (RX)							
P67	Multi-function input terminal P2 define		2	EST-Emergency Stop Trip : temporary output cut-off					1	0	
P68	Multi-function input terminal P3 define		3	Reset when a fault occurs(RST)					2	0	
			4	Jog operation command (JOG)							
P69	Multi-function input terminal P4 define		5	Multi-Step freq – low					3	0	
			6	Multi-Step freq – high							
P70	Multi-function input terminal P5 define		7	-					4	0	
			8	-							
			9	-							
			10	-							
			11	DC brake during stop							
			12	-							
			13	-							
			14	-							
			15	Up-down	Frequency up						
			16		Frequency down						
			17	3-wire operation							
			18	External trip: A Contact (EtA)							
			19	External trip: B Contact (EtB)							
			20	Change from PI operation to general operation							
			21	-							
			22	Analog Hold							
			23	Accel/Decel Disable							
24	Up/Down Save Freq. Initialization										
P71	Input terminal status display	-	BIT4	BIT3	BIT2	BIT1	BIT0	-	-		
			P5	P4	P3	P2	P1				

## Chapter 7. Function List

Display	Name	Min/Max range	Description	Factory defaults	Adj. during run		
P72	Filtering time constant for Multi-function Input terminal	1 ~ 20	If the value is set higher, the responsiveness of the Input terminal is getting slower.	3	0		
P73	Analog output item select	0 ~ 3		Output item	Output to 10[V]	0	0
			0	Output freq.	Max frequency		
			1	Output current	150 %		
			2	Output voltage	282 V		
			3	Inverter DC link voltage	DC 400V		
P74	Analog output level adjustment	10 ~ 200 [%]	Based on 10V.	100	0		
P75	Frequency detection level	0 ~ 200 [Hz]	Used when P77 is set to 0-4. Cannot be set higher than P16.	30.00	0		
P76	Frequency detection bandwidth			10.00	0		
P77	Multi-function relay select	0 ~ 17	0	FDT-1	17	0	
			1	FDT-2			
			2	FDT-3			
			3	FDT-4			
			4	FDT-5			
			5	-			
			6	Inverter Overload (IOLt)			
			7	Motor stall (STALL)			
			8	Over voltage trip (OVt)			
			9	Low voltage trip (LVt)			
			10	Inverter cooling pin Overheat (Oht)			
			11	Command loss			
			12	During Run			
			13	During Stop			
			14	During constant run			
			15	During speed searching			
			16	Wait time for run signal input			
17	Fault output select						



Display	Name	Min/Max range	Description			Factory defaults	Adj. during run	
P78	Fault output select	0 ~ 7 [bit]	Func	Operation when setting the number of auto restart try(P38)	Operation when the trip other than low voltage trip occurs	Operation when the low voltage trip occurs	2	0
			Set	bit 2	bit 1	bit 0		
			0	-	-	-		
			1	-	-	✓		
			2	-	✓	-		
			3	-	✓	✓		
			4	✓	-	-		
			5	✓	-	✓		
			6	✓	✓	-		
7	✓	✓	✓					
P79	Inverter number	1 ~ 250	Set for RS-485 communication			1	0	
P80	Baud rate	0 ~ 2	Select the Baud rate of the RS-485.			2	0	
			0	2400 [bps]				
			1	4800 [bps]				
P81	Drive mode select after loss of frequency command	0 ~ 2	It is used when freq command is given via Analog signal(volume/AI) or RS-485.			0	0	
			0	Continuous operation at the frequency before its command is lost.				
			1	Free Run stop (Output cut-off)				
P82	Wait time after loss of frequency command	0.1 ~ 120 [sec]	Time inverter determines whether there is the input frequency command or not. If there is no frequency command input during this time, inverter starts operation via the mode selected at P81.			1.0	0	
			2	Decel to stop				
P83	Communication time setting	2 ~ 100 [ms]	When RS-485 communication, waiting time from TX to the next TX.			5	0	

## Chapter 7. Function List

Display	Name	Min/Max range	Description		Factory defaults	Adj. during run	
P84	Parity/stop bit setting	0 ~ 3	Sets communication parity and stop bit.		0	O	
				Parity bit			Stop bit
			0	-			1 Stop Bit
			1	-			2 Stop Bit
			2	Odd Parity			1 Stop Bit
3	Even Parity	1 Stop Bit					
P85	Parameter initialization	0 ~ 3	Initialize the parameters set by a user to factory defaults		0	X	
			0	-			
			1	Initialize both groups			
			2	Initialize Drive Group			
3	Initialize PG Group						
P86	Password registration	0 ~ FFFF	Enter password to prohibit parameter change. Set it as hexadecimal number		0	O	
P87	parameter change prohibition	0 ~ FFFF	Prohibit or cancel parameter change prohibition by using the password set in P86.		0	O	
			UL(Unlock)	Enable parameter change			
			L(Lock)	Disable parameter change			
P88	Software version	-	Display inverter software version. Refer to manual version.		-	X	
P89	Selecting communication protocol	0 ~ 1	0 : Modbus RTU 1 : LSBUS		0	X	









## 8. Troubleshooting and Maintenance

### 8.1 Protective Functions

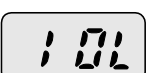
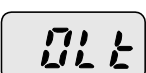
#### **Caution**



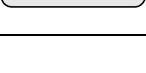

When a fault occurs, the cause must be corrected before the fault can be cleared. If protective function keeps active, the inverter should restart after clearing the cause(s). Or, it may lead to reduction in product life and damage to the equipment.

- Protection of Inverter output current and input voltage

Fault display	Protective function	Description
	Overcurrent	The inverter turns off its output when the output current of the inverter flows more than 200% of the inverter rated current.
	Ground fault current	The inverter turns off its output when a ground fault occurs on the output as long as the function is active.
	Ground fault current	The inverter turns off its output when unbalanced output current occurs due to abnormal situation such as ground fault during run and one of U,V,W gets overcurrent.
	Inverter Overload	The inverter turns off its output when the output current of the inverter flows more than the rated level (150% for 1 minute).
	Overload trip	The inverter turns off its output if the output current of the inverter more than the motor rated current(P25) flows.
	Inverter overheat	The inverter turns off its output if the heat sink overheats due to a damaged cooling fan.
	Condenser overload	Inverter output is blocked when one of 3 phases gets opened or main condenser is outworn, resulting in excessive DC voltage variation. Detection time varies depending on inverter output current.
	Output Phase loss	The inverter turns off its output when the one or more of the output (U, V, W) phase is open. The inverter detects the output current to check the phase loss of the output.
	Over voltage	The inverter turns off its output if the DC voltage of the main circuit increases higher than 400 V when the motor decelerates. This fault can also occur due to a surge voltage generated at the power supply system.
	Low voltage	The inverter turns off its output if the DC voltage is below 180V because of insufficient voltage input torque.

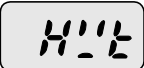
## Chapter 8. Troubleshooting and Maintenance

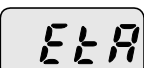
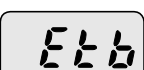
- Protection of abnormal internal circuit and external signal









Fault display	Protective function	Description
	Parameter save error	Displayed when user-setting parameters fail to be entered into memory.
	Inverter hardware fault	Displayed when an error occurs in CPU operation and internal OS program. The fault may not be relieved simply by STOP/RST key of the loader or reset terminal. Retry after completely turning off the inverter and the display of the loader is fully disappeared.
	Instant cut off	Used for the emergency stop of the inverter. The inverter instantly turns off the output when the EST terminal is turned on. <b>Note</b> The inverter starts to regular operation when turning off the EST terminal while FX or RX terminal is ON.
	External fault A contact input	When multi-function input terminal (P66~P70) is set to 18, external fault signal input: A (Normal Open Contact), the inverter turns off the output.
	External fault B contact input	When multi-function input terminal (P66 ~ P70) is set to 19, external fault signal input: B (Normal Close Contact), the inverter turns off the output.
	When the frequency command is lost	When inverter operation is set via Analog input (0-10V or 0-20mA input) or option (RS-485) and no signal is applied, operation is done according to the method set in P81.

## 8.2 Fault Remedy











### Caution

If any trouble occurs due to overcurrent, make sure to restart after eliminating the causes because power semiconductor element inside the inverter may be broken.

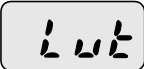
Protective function	Cause	Remedy				
 Overcurrent	<ul style="list-style-type: none"> <li>● Accel/Decel time is too short compared to the inertia of the load(<math>GD^2</math>).</li> <li>● Load is greater than the inverter rating.</li> <li>● Inverter output is issued when the motor is free running.</li> <li>● Output short circuit or ground fault has occurred.</li> <li>● Mechanical brake of the motor is operating too fast.</li> </ul>	<ul style="list-style-type: none"> <li>☞ Increase the Accel/Decel time.</li> <li>☞ Replace the inverter with appropriate capacity.</li> <li>☞ Resume operation after stopping the motor or use P36 (Speed search).</li> <li>☞ Check output wiring.</li> <li>☞ Check the mechanical brake.</li> </ul>				
  Ground fault current	<ul style="list-style-type: none"> <li>● Ground fault has occurred at the output wiring of the inverter.</li> <li>● The insulation of the motor is damaged due to heat.</li> </ul>	<ul style="list-style-type: none"> <li>☞ Check the wiring of the output terminal.</li> <li>☞ Replace the motor.</li> </ul>				
 Inverter overload	<ul style="list-style-type: none"> <li>● Load is greater than the inverter rating.</li> <li>● Torque boost scale is set too large.</li> </ul>	<ul style="list-style-type: none"> <li>☞ Upgrade the capacity of motor and inverter or reduce the load weight.</li> <li>☞ Reduce torque boost scale.</li> </ul>				
 Overload trip			 Inverter overheat	<ul style="list-style-type: none"> <li>● Cooling system has faults.</li> <li>● Ambient temperature is too high.</li> </ul>	<ul style="list-style-type: none"> <li>☞ Check for alien substances clogged in the heat sink.</li> <li>☞ Keep ambient temperature under 40°C.</li> </ul>	 Condenser overload
 Inverter overheat	<ul style="list-style-type: none"> <li>● Cooling system has faults.</li> <li>● Ambient temperature is too high.</li> </ul>	<ul style="list-style-type: none"> <li>☞ Check for alien substances clogged in the heat sink.</li> <li>☞ Keep ambient temperature under 40°C.</li> </ul>				
 Condenser overload	<ul style="list-style-type: none"> <li>● 3-Phase product may have one phase lost.</li> <li>● Internal condenser was outworn.</li> </ul>	<ul style="list-style-type: none"> <li>☞ Check whether wiring of input power or inter-phase voltage is abnormal.</li> <li>☞ It's almost time to replace or it may happen when it is used in hot temperature for a long while. Contact after-sales service.</li> </ul>				

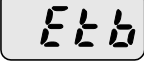
## Chapter 8. Troubleshooting and Maintenance

### ● Fault Remedy

Protective function	Cause	Remedy
 Output Phase loss	<ul style="list-style-type: none"> <li>● Faulty contact of magnetic switch at output</li> <li>● Faulty output wiring</li> </ul>	<ul style="list-style-type: none"> <li>☞ Make connection of magnetic switch at output of the inverter securely.</li> <li>☞ Check output wiring.</li> </ul>
 Over voltage	<ul style="list-style-type: none"> <li>● Decel time is too short compared to the inertia of the load(<math>GD^2</math>).</li> <li>● Regenerative load is at the inverter output.</li> <li>● Line voltage is too high.</li> </ul>	<ul style="list-style-type: none"> <li>☞ Increase the Decel time.</li> <li>☞ Check whether line voltage exceeds its rating.</li> </ul>
 Low voltage	<ul style="list-style-type: none"> <li>● Line voltage is low.</li> <li>● Load larger than line capacity is connected to line (ex: welding machine, motor's direct input)</li> <li>● Faulty magnetic switch at the input side of the inverter.</li> </ul>	<ul style="list-style-type: none"> <li>☞ Check whether line voltage is below its rating.</li> <li>☞ Check the incoming AC line. Adjust the line capacity corresponding to the load.</li> <li>☞ Change a magnetic switch.</li> </ul>
 External fault A contact input	<ul style="list-style-type: none"> <li>● The multi function terminals(P66 ~ P70) set to "18 (External fault-A)" or "19 (External trip signal input : fault-B)" in P66~P70 in PG Group is ON.</li> </ul>	<ul style="list-style-type: none"> <li>☞ Eliminate the cause of fault at circuit connected to external fault terminal or cause of external fault input.</li> </ul>
 External fault B contact input		
	<ul style="list-style-type: none"> <li>● No frequency command is applied to AI terminal.</li> <li>● Communication command is cuts off</li> </ul>	<ul style="list-style-type: none"> <li>☞ Check the wiring of AI and frequency reference level.</li> <li>☞ In case of a program set to periodically update frequency, check the communication line or operation of master device.</li> </ul>
  Parameter save error Hardware fault		<ul style="list-style-type: none"> <li>☞ Contact your local LSIS sales representative.</li> <li>☞ EEP message occurs when first allowing power after upgrading software due to A/S service. At the moment, turn it off and retry.</li> </ul>

### 8.3 Precautions for maintenance



#### Warning

- Make sure to remove the input power while performing maintenance.
- Make sure to perform maintenance after checking the DC link capacitor has discharged. The bus capacitors in the inverter main circuit can still be charged even after the power is turned off. Check the voltage between terminal P or P1 and N using a tester before proceeding.
- SV-iE5 series inverter has ESD (Electrostatic Discharge) sensitive components. Take protective measures against ESD before touching them for inspection or installation.
- Do not change any inner parts and connectors. Never modify the inverter.

### 8.4 Checklist

- Daily inspections
  - ▶ Proper installation environment
  - ▶ Cooling system fault
  - ▶ Unusual vibration and noise
  - ▶ Unusual overheating and discoloration
- Periodic inspection
  - ▶ Do screws and bolts become loose or rust due to the environment?
    - ☞ Tighten or replace them.
  - ▶ Alien substances are clogged in the cooling system?
    - ☞ Eliminate them by using compressed air.
  - ▶ Check the rotating condition of the cooling fan, the condition of capacitors and the connections with the magnetic contactor
    - ☞ Replace them if there are any abnormalities.

### 8.5 Parts Replacement

The inverter consists of many electronic parts such as semiconductor devices. The following parts may deteriorate with age because of their structures or physical characteristics, leading to reduced performance or failure of the inverter. For preventive maintenance, the parts must be changed periodically.

Part name	Change period (year)	Description
DC link condenser	4	Exchange
Control smoothing condenser	4	Exchange
Relay	-	Determined after inspection



## 9. Specifications

### 9.1 Technical data

- Input and output ratings

Type : SV xxx iE5 – x		001-1	002-1	004-1	001-2	002-2	004-2
1) Motor	[HP]	1/8	1/4	1/2	1/8	1/4	1/2
	[kW]	0.1	0.2	0.4	0.1	0.2	0.4
Output ratings	2) Capacity[kVA]	0.3	0.6	0.95	0.3	0.6	1.14
	Current [A]	0.8	1.4	2.5	0.8	1.6	3.0
	Output frequency	0 ~ 200 [Hz]					
	Voltage [V]	3) 3phase 200 ~ 230V					
Input ratings	Voltage [V]	1phase 200 ~ 230 VAC (±10%)			3phase 200~230 VAC (±10%)		
	Frequency	50 ~ 60 [Hz] (±5%)					
	Current[A]	2.0	3.5	5.5	1.2	2.0	3.5

- Control

Control method	v/f
Frequency setting resolution	Digital command : 0.01Hz Analog command : 0.1Hz (max. fre : 60Hz)
Frequency accuracy	Digital command: 0.01% of Max output frequency Analog command: 0.1% of Max output frequency
v/f pattern	Linear v/f, Squared v/f
Overload capacity	150% per min.
Torque boost	Manual/Auto torque boost

1) Motor shows the max. capacity assuming that 4 poles standard motor is used.

2) Ratings are based on 220V.

3) Max. output voltage may not be over the power voltage. Output voltage may be set temporarily lower than the power voltage.

## Chapter 9. Specifications

### ● Operation

Operation mode		Select one of loader/terminal/COM operation(optional)	
Frequency setting		Analogue: 0 ~ 10[V], 0 ~ 20[mA], loader volume Digital: loader	
Operation features		PI, up-down, 3-wire	
Input	Multi-function terminal P1, P2, P3, P4, P5	NPN / PNP selectable (see page 3-5)	
		Functions: FWD/REV RUN, Emergency stop, Fault reset, Jog operation, Multi-step Frequency-High & Low, Frequency UP/Down, 3-wire operation, External trip A & B, PI-Inverter (v/f) operation bypass, Analog Hold, Accel/Decel stop, Up/Down Save Freq.	
	Multi-function relay	Fault output and inverter status output	Less than (N.O., N.C.) AC250V 0.3A Less than DC 30V 1A
Analog output		0 ~ 10 Vdc (less than 10mA) : frequency, current, voltage, DC voltage selectable	

### ● Protective function

Trip	Over Voltage, low voltage, over current, ground fault detection, inverter overload, overload trip, inverter overheat, condenser overload, output phase loss, overload protection, frequency command loss, hardware fault.
Alarm	Stall prevention
Momentary power loss	Below 15 msec: Continuous operation (should be within rated input voltage, rated output power.) Above 15 msec: Auto restart enable

### ● Structure and Environment

Cooling	Natural cooling
Protection type	Open(IP 20)
Ambient temperature	-10°C ~ 40°C
Storage temperature	-20°C ~ 65°C
Ambient humidity	Less than 90% RH (non-condensing)
Altitude, vibration	Below 1,000m, below 5.9m/sec <sup>2</sup> (0.6G)
Environmental conditions	Protected from corrosive gas, combustible gas, oil mist or dust

**EC DECLARATION OF CONFORMITY**

---

We, the undersigned,

Representative: **LSIS Co., Ltd.**  
Address: **LS Tower, Hoge-dong, Dongan-gu,  
Anyang-si, Gyeonggi-do 1026-6,  
Korea**

Manufacturer: **LSIS Co., Ltd.**  
Address: **181, Samsung-ri, Mokchon-Eup,  
Chonan, Chungnam, 330-845,  
Korea**

Certify and declare under our sole responsibility that the following apparatus:

Type of Equipment: **Inverter (Power Conversion Equipment)**

Model Name: **STARVERT-iE5 series**

Trade Mark: **LSIS Co., Ltd.**

conforms with the essential requirements of the directives:

2006/95/EC Directive of the European Parliament and of the Council on the harmonisation of the laws of Member States relating to Electrical Equipment designed for use within certain voltage limits

2004/108/EC Directive of the European Parliament and of the Council on the approximation of the laws of the Member States relating to electromagnetic compatibility

based on the following specifications applied:

**EN 61800-3:2004  
EN 61800-5-1:2007**

and therefore complies with the essential requirements and provisions of the 2006/95/CE and 2004/108/CE Directives.

Place: **Chonan, Chungnam,  
Korea**

 2012. 7. 3 (Signature /Date)

**Mr. In Sik Choi / General Manager**  
(Full name / Position)

### TECHNICAL STANDARDS APPLIED

The standards applied in order to comply with the essential requirements of the Directives 2006/95/CEE "Electrical material intended to be used with certain limits of voltage" and 2004/108/CEE "Electromagnetic Compatibility" are the following ones:

• EN 50178 (1997)	“Electronic equipment for use in power installations”.
•EN 61800-3/ (2004)	“Adjustable speed electrical power drive systems. Part 3: EMC product standard including specific methods”
• EN 55011/A2 (2003)	“Industrial, scientific and medical (ISM) radio-frequency equipment. Radio disturbances characteristics. Limits and methods of measurement”
•EN61000-4-2/A2 (2001)	“Electromagnetic compatibility (EMC). Part 4: Testing and measurement techniques. Section 2: Electrostatic discharge immunity test.
•EN61000-4-3/A2 (2004)	“Electromagnetic compatibility (EMC). Part 4: Testing and measurement techniques. Section 3: Radiated, radiofrequency, electromagnetic field immunity test.
•EN61000-4-4/A2 (2002)	“Electromagnetic compatibility (EMC). Part 4: Testing and measurement techniques. Section 4: Electrical fast transients / burst immunity test.
•EN61000-4-5/A1 (2001)	“Electromagnetic compatibility (EMC). Part 4: Testing and measurement techniques. Section 5: Surge immunity test.
•EN61000-4-6/A1 (2001)	“Electromagnetic compatibility (EMC). Part 4: Testing and measurement techniques. Section 6: Immunity to conducted disturbances, induced by radio-frequency fields.
•CEI/TR 61000-2-1 (1990)	“Electromagnetic compatibility (EMC). Part 2: Environment. Environment description for low-frequency conducted disturbances and signalling in public low voltages supply systems”
• EN 61000-2-2 (2003)	“Electromagnetic compatibility (EMC). Part 2: Environment. Compatibility level for low-frequency conducted disturbances and signalling in public low voltages supply systems”

## DECLARATION OF CONFORMITY

### EMI / RFI POWER LINE FILTERS

LS inverters, iE5 series

#### RFI FILTERS



THE LS RANGE OF POWER LINE FILTERS FF ( Footprint ) - FE ( Standard ) SERIES, HAVE BEEN SPECIFICALLY DESIGNED WITH HIGH FREQUENCY LG INVERTERS. THE USE OF LS FILTERS, WITH THE INSTALLATION ADVICE OVERLEAF HELP TO ENSURE TROUBLE FREE USE ALONG SIDE SENSITIVE DEVICES AND COMPLIANCE TO CONDUCTED EMISSION AND IMMUNITY STANDARDS TO EN 50081.

#### CAUTION

THE LS RANGE OF POWER LINE FILTERS FF ( Footprint ) - FE ( Standard ) SERIES, HAVE BEEN SPECIFICALLY DESIGNED WITH HIGH FREQUENCY LG INVERTERS. THE USE OF LS FILTERS, WITH THE INSTALLATION ADVICE OVERLEAF HELP TO ENSURE TROUBLE FREE USE ALONG SIDE SENSITIVE DEVICES AND COMPLIANCE TO CONDUCTED EMISSION AND IMMUNITY STANDARDS TO EN 50081.

### RECOMMENDED INSTALLATION INSTRUCTIONS

To conform to the EMC directive, it is necessary that these instructions be followed as closely as possible. Follow the usual safety procedures when working with electrical equipment. All electrical connections to the filter, inverter and motor must be made by a qualified electrical technician.

- 1-) Check the filter rating label to ensure that the current, voltage rating and part number are correct.
- 2-) For best results the filter should be fitted as closely as possible to the incoming mains supply of the wiring enclosure, usually directly after the enclosures circuit breaker or supply switch.
- 3-) The back panel of the wiring cabinet or board should be prepared for the mounting dimensions of the filter. Care should be taken to remove any paint etc... from the mounting holes and face area of the panel to ensure the best possible earthing of the filter.
- 4-) Mount the filter securely.
- 5-) Connect the mains supply to the filter terminals marked LINE, connect any earth cables to the earth stud provided. Connect the filter terminals marked LOAD to the mains input of the inverter using short lengths of appropriate gauge cable.
- 6-) Connect the motor and fit the ferrite core ( output chokes ) as close to the inverter as possible. Armoured or screened cable should be used with the 3 phase conductors only threaded twice through the center of the ferrite core. The earth conductor should be securely earthed at both inverter and motor ends. The screen should be connected to the enclosure body via an earthed cable gland.
- 7-) Connect any control cables as instructed in the inverter instructions manual.

IT IS IMPORTANT THAT ALL LEAD LENGTHS ARE KEPT AS SHORT AS POSSIBLE AND THAT INCOMING MAINS AND OUTGOING MOTOR CABLES ARE KEPT WELL SEPARATED.

FF SERIES ( Footprint )

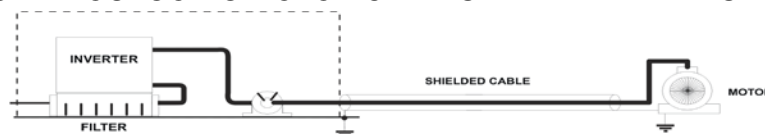

FE SERIES ( Standard )



# DECLARATION OF CONFORMITY

iE5 series / Footprint Filters										
INVERTER	POWER	CODE	CURRENT	VOLTAGE	LEAKAGE CURRENT	DIMENSIONS L W H	MOUNTING Y X	WEIGHT	MOUNT	OUTPUT CHOKES
SINGLE PHASE (max.)										
SV001iE5-1	0.1kW	FFE5-M010-1	10A	250VAC	3.5mA	176 x 75.5 x 39	162 x 52	0.5 Kg	M4	FS - 1
SV002iE5-1	0.2kW									
SV004iE5-1	0.4kW									
THREE PHASE NOM. MAX.										
SV001iE5-2	0.1kW	FFE5-T006-1	6A	250VAC	0.3mA 18mA	176 x 75.5 x 39	162 x 52	0.6 Kg	M4	FS - 2
SV002iE5-2	0.2kW									
SV004iE5-2	0.4kW									

iE5 series / Standard Filters										
INVERTER	POWER	CODE	CURRENT	VOLTAGE	LEAKAGE CURRENT	DIMENSIONS L W H	MOUNTING Y X	WEIGHT	MOUNT	OUTPUT CHOKES
SINGLE PHASE (max.)										
SV001iE5-1	0.1kW	FE-M010-(x)	10A	250VAC	3.5mA	150 x 55 x 45	140 x 36	0.6 Kg	---	FS - 1
SV002iE5-1	0.2kW									
SV004iE5-1	0.4kW									
THREE PHASE NOM. MAX.										
SV001iE5-2	0.1kW	FE-T006-(x)	6A	250VAC	0.3mA 18mA	250 x 110 x 60	238 x 76	1.6 Kg	---	FS - 2
SV002iE5-2	0.2kW									
SV004iE5-2	0.4kW									

- (x) (1) Industrial environment EN50081-2 (A class)  
 (2) Domestic and industrial environment EN50081-1 (B class)

FF SERIES ( Footprint )

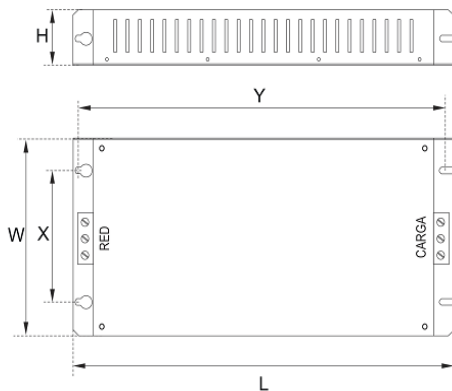

FE SERIES ( Standard )

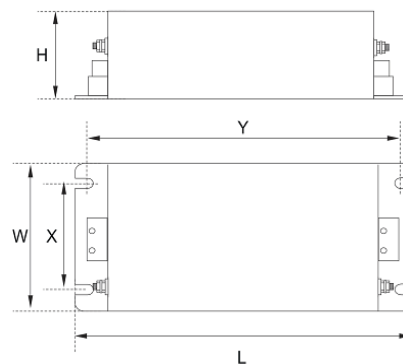

Vector Motor Control Ibérica S.L.  
 C/ Mar del Carib, 10  
 Pol. Ind. La Torre del Rector  
 08130 Santa Perpètua de Mogoda  
 (BARCELONA) ESPAÑA  
 Tel. (+34) 935 748 206  
 Fax (+34) 935 748 248  
 info@vmc.es  
 www.vmc.es

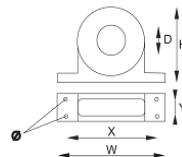

FS SERIES ( output chokes )

TYPE	D	W	H	X	Ø
FS - 1	21	85	46	70	5
FS - 2	28.5	105	62	90	5

PR0061

## UL Marking

### 1. SHORT CIRCUIT RATING

The drive is suitable for use in a circuit capable of delivering not more than 5,000A RMS at the drive's maximum rated voltage.

(L'entraînement convient pour une utilisation dans un circuit capable de délivrer pas plus de 5,000A RMS à la tension nominale maximale de l'entraînement.)

### 2. SHORT CIRCUIT FUSE/BREAKER MARKING

Use Class H or RK5 UL listed Input fuses and UL listed breakers ONLY. See the table above for the voltage and current ratings for the fuses and breakers.

(Utiliser UNIQUEMENT des fusibles d'entrée homologués de Classe H ou RK5 UL et des disjoncteurs UL. Se reporter au tableau ci-dessus pour la tension et le courant nominal des fusibles et des disjoncteurs.)

### 3. FIELD WIRING TERMINAL

- 1) Use copper wires only with 75°C ratings for wiring.

(Utiliser uniquement des fils de cuivre avec une valeur nominale de 75 °C pour le câblage de la borne d'alimentation.)

- 2) Apply rated torques to the terminal screws. Loose screws may cause short circuits and malfunctions. Tightening the screw too much may damage the terminals and cause short circuits and malfunctions.

(Appliquer des couples de marche aux vis des bornes. Des vis desserrées peuvent provoquer des courts-circuits et des dysfonctionnements. Ne pas trop serrer la vis, car cela risque d'endommager les bornes et de provoquer des courts-circuits et des dysfonctionnements.)

## EAC mark



The EAC (EurAsian Conformity) mark is applied to the products before they are placed on the market of the Eurasian Customs Union member states.

It indicates the compliance of the products with the following technical regulations and requirements of the Eurasian Customs Union:

Technical Regulations of the Customs Union 004/2011 “On safety of low voltage equipment”

Technical Regulations of the Customs Union 020/2011 “On electromagnetic compatibility of technical products”



## WARRANTY

Maker	LSIS Co.,Ltd		Installation (start-up) date	
Model No.	SV-iE5		Warranty period	
Customer info	Name			
	Address			
	Tel.			
Sales office	Name			
	Address			
	Tel.			

### Note

This product has been manufactured through the strict QC control and inspection of LSIS. Warranty period is 12 months after installation or 18 months after manufactured when the installation date is unidentified. However, the guarantee term may vary on the sales term.

- In-warranty service information
  - ▶ If the defective part has been identified under normal and proper use within the guarantee term, contact your local authorized LS distributor or LS Service center.
- Out-of-warranty service information
  - ▶ The guarantee will not apply in the following cases.
    - ▶ Troubles are attributable to a user's intentional negligence or carelessness.
    - ▶ Damage was caused by abnormal voltage and peripheral devices' malfunction (failure).
    - ▶ Damage was caused by natural disasters(earthquake, fire, flooding, lightning and etc).
    - ▶ When LS nameplate is not attached.

## Manual Revision History

No.	Revision	Changes	Version. No	Remarks
1	Sept 2006	First edition	1.10	-
2	Jan 2007	Contents revised	1.10	-
3	Apr 2007	Contents revised	1.20	-
4	Jul 2008	Contents revised	1.30	-



● **Sustainable Management**

LS Industrial System Co.,Ltd take the highest priority on sustainable management and do our best to preserve the environment of the earth.

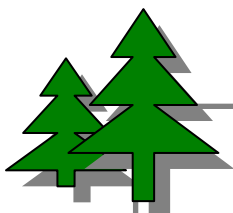

● **Disposal Recommendation**

LS Inverter is intended and designed to preserve the environment. To dispose of it, iron, aluminum, copper, and synthetic resin(product cover) may be separated and reused.